



ARKEL

KM-10

ELEVATOR DOOR CONTROLLER



USER MANUAL

Publisher

ARKEL Elektrik Elektronik Ticaret Ltd. Şti.

Şerifali Mah. Bayraktar Bulvarı Sehit Sk. No:32 Umraniye Istanbul TURKIYE

Tel: (+90 216) 540 67 24

Fax: (+90 216) 540 03 09

E-mail: info@arkel.com.tr

www.arkel.com.tr

Date of issue

06.2013

Document version

V1.02

Hardware version

V1.02

Software version

V5.00

CONTENTS

| | | |
|-----------|--|-----------|
| 1 | INTRODUCTION | 4 |
| 2 | TECHNICAL SPECIFICATIONS | 5 |
| 3 | OVERVIEW OF KM-10 DOOR CONTROLLER | 6 |
| 4 | DESCRIPTION OF TERMINALS..... | 7 |
| 5 | DESCRIPTION OF LED'S | 8 |
| 6 | GENERAL WARNINGS..... | 9 |
| 7 | CONNECTION DIAGRAM | 10 |
| 8 | CONTROL INPUTS CONNECTION | 11 |
| 8.1 | CONTROL INPUTS CONNECTION WITH INTERNAL SUPPLY..... | 11 |
| 8.2 | CONTROL INPUTS CONNECTION WITH EXTERNAL SUPPLY | 11 |
| 9 | ONBOARD KEYPAD & DISPLAY..... | 12 |
| 9.1 | KEYPAD AND LCD DISPLAY | 12 |
| 9.2 | KM-10 KEYPAD FUNCTIONS | 12 |
| 9.3 | MONITORING & OPERATION SCREENS | 13 |
| 10 | ACCESSING MENU | 15 |
| 11 | PARAMETERS..... | 16 |
| 12 | PARAMETER SETTING VIA KM-10 KEYPAD | 17 |
| 12.1 | GENERAL PARAMETER SETTINGS | 17 |
| 12.2 | DOOR OPENING SETTINGS | 20 |
| 12.3 | DOOR CLOSING SETTINGS | 21 |
| 12.4 | MOTOR SETTINGS | 22 |
| 12.5 | PI SPEED REGULATOR ADJUSTMENT | 23 |
| 13 | EMERGENCY OPERATION..... | 24 |
| 14 | NUDGING OPERATION..... | 24 |
| 16 | STATUS MESSAGES | 25 |
| 17 | ERROR MESSAGES | 26 |
| 18 | TROUBLESHOOTING | 27 |
| 19 | DIMENSIONS | 29 |

1 INTRODUCTION

KM-10 controller is an “intelligent” door control board designed for automatic telescopic lift doors with 24VDC reduction gear motor. It provides advance features for high comfort, high dynamic performance and flexible usage.

- KM-10 provides complete hold of the motor with its 4-region motor control and high resolution encoder input hardware.
- In addition to this hardware, it allows swift but comfortable motion of doors with its software that provides S-softening in travel ramps and which has the algorithm that does not require limit switches.
- It provides features for auto-learning of door travel limits without open-close limit switches.
- In order to work with the control panels in complete harmony it can generate “Doors are completely open”, “Doors are fully closed” and “Obstruction or photocell detected” signals.
- Compatible with fire lift doors.
- A nudging function is included with buzzer sound and slow speed closing after a long time photocell interrupt.
- In case of mains failure, it can get the power from batteries or 24VDC external supply.
- It provides a parameter menu which has access levels for security, user/customer needs and easy adjustment.
- It provides many functions and parameters for manufacturing companies that enable application flexibility, like motor reduction ratio, motor revolution, motor sheave circumference and skate open zone.
- It provides user friendly parameter setting with speed units in cm/s and travel distance units in cm.
- It provides a counter for the information of opening-closing times.
- Internal keypad and display allows access to all its parameters, functionality and monitoring screens.
- Availability of multiple languages: Turkish, English and Greek

2 TECHNICAL SPECIFICATIONS

Input supply:

| | |
|-------------------------|-------------------------------------|
| Supply voltage: | 20VAC±10% |
| Max. Power consumption: | 10W (control circuit) + Motor power |
| Supply protection: | Short-circuit protection (8A) |

Motor outputs:

| | |
|---------------------|---|
| Motor voltage: | 24VDC |
| Motor output power: | Max. 200W (8A) |
| Motor control type: | 4-region motor control |
| Motor protection: | Motor output overload and short circuiting protection |

Encoder inputs:

| | |
|---------------------|--|
| Encoder type: | Incremental (2-channel incremental encoder) |
| Encoder resolution: | Any model between 100 pulse and 2048 pulse |
| Encoder voltage: | 5V DC |

Note: Encoder is not included

Output signals:

| | |
|-----------------------------|---|
| Outputs for control panels: | Door open signal Door closed signal Door obstruction or photocell detected signal |
| Output type: | with relay contact output 3A @ 250V AC or 30V DC |

Input signals:

| | |
|---|---|
| Door control & speed signals: (Opto-coupled) | Open signal Close signal |
| Other inputs: | Photocell & obstruction signal NDG signal to activate nudging mode |
| Input type: | Activated with 24VDC |

Battery connection:

| | |
|--------------------------|------------------------------|
| Battery voltage: | 2 pieces 12V/1.2Ah batteries |
| Internal battery charge: | Not Included |
| Battery protection: | - With fuse |

User interface:

| | |
|---------------------|-----------------------------------|
| Standard interface: | 2x16 Character display and 4 keys |
| Warning sound: | With buzzer |
| Language options: | Turkish, English, Greek |

Mechanical features:

| | |
|-------------|---|
| Dimensions: | 116 x 160 x 50 mm (width x length x height) |
|-------------|---|

Working capability:

| | |
|------------------------------------|------------------|
| Door opening: | 50cm – 300cm |
| Motor power | Max 200W |
| Door opening-closing velocity: | 20cm/s - 50 cm/s |
| Door opening-closing slow velocity | 2cm/s – 19 cm/s |

3 OVERVIEW of KM-10 DOOR CONTROLLER

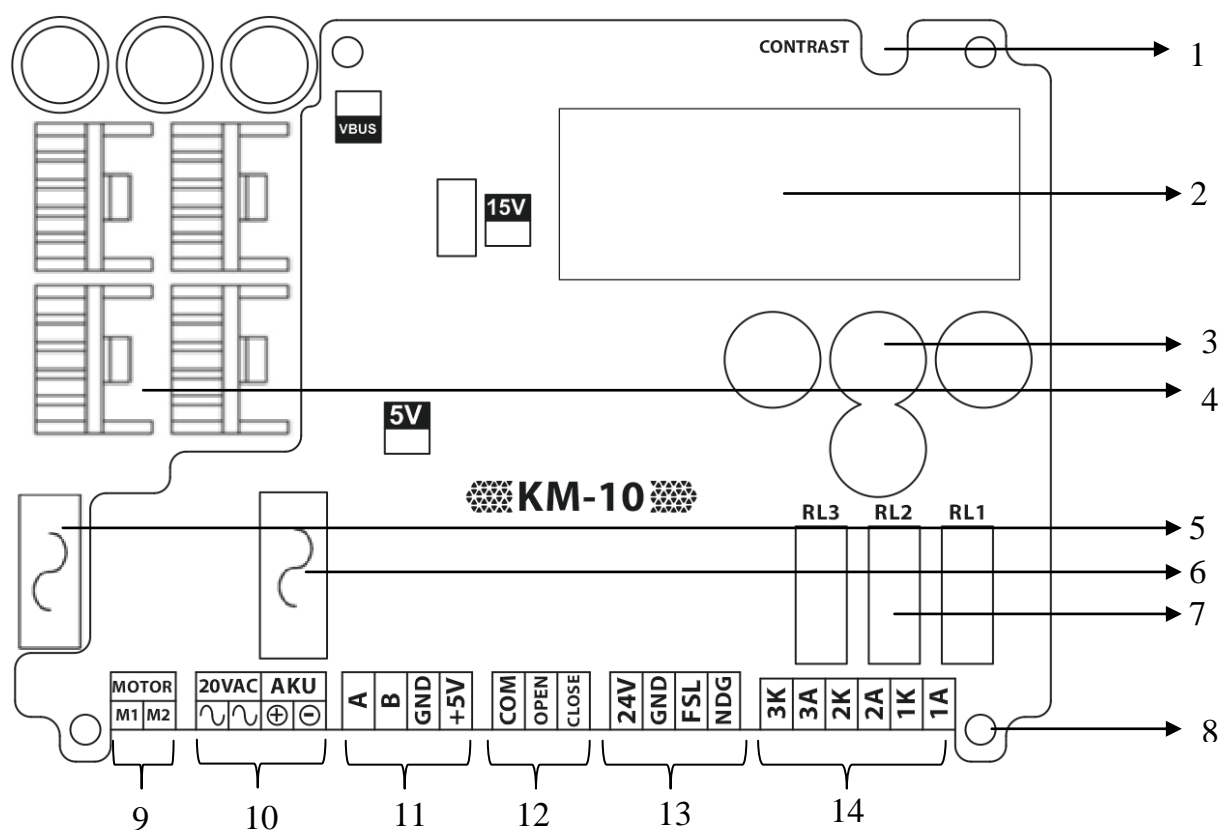

Figure-1: KM-10 layout

- 1- LCD Contrast adjustment
- 2- 2x16 character display
- 3- 4-button keypad
- 4- Motor driving transistors with coolers
- 5- Ac input supply fuse
- 6- Battery supply fuse
- 7- Door is fully open & closed, door re-open (door obstruction or photocell) relays
- 8- Assembly holes
- 9- Motor output terminals
- 10- AC power supply and emergency supply terminals
- 11- Encoder input terminals
- 12- Door control input terminals
- 13- Photocell input and NDG input terminals
- 14- Relay output terminals

4 DESCRIPTION of TERMINALS

Motor output

MOT : Motor output
Motor output

AC power supply input

20Vac : 18-22VAC power supply input

Emergency supply input

AKU + : +24VDC emergency supply (Battery or external supply)
- : -24VDC

Encoder terminals

A : Encoder channel A
B : Encoder channel B
GND : GND
+5V : +5V

Control signals

COM : Common of control signals
OPEN : Open signal
CLOSE : Close signal

Other input terminals

+24V : +24Vdc internal supply for input signals
GND : Ground for internal supply (0Vdc)
FSL : Photocell signal
NDG : Nudging mode signal

Relay output terminals

3A : Reopening (Obstruction or photocell) contact output (NO)
3O : Reopening contact common
2A : Door closed contact output (NO)
2O : Door closed contact common
1A : Door open contact output (NO)
1O : Door open contact common

5 DESCRIPTION of LED'S

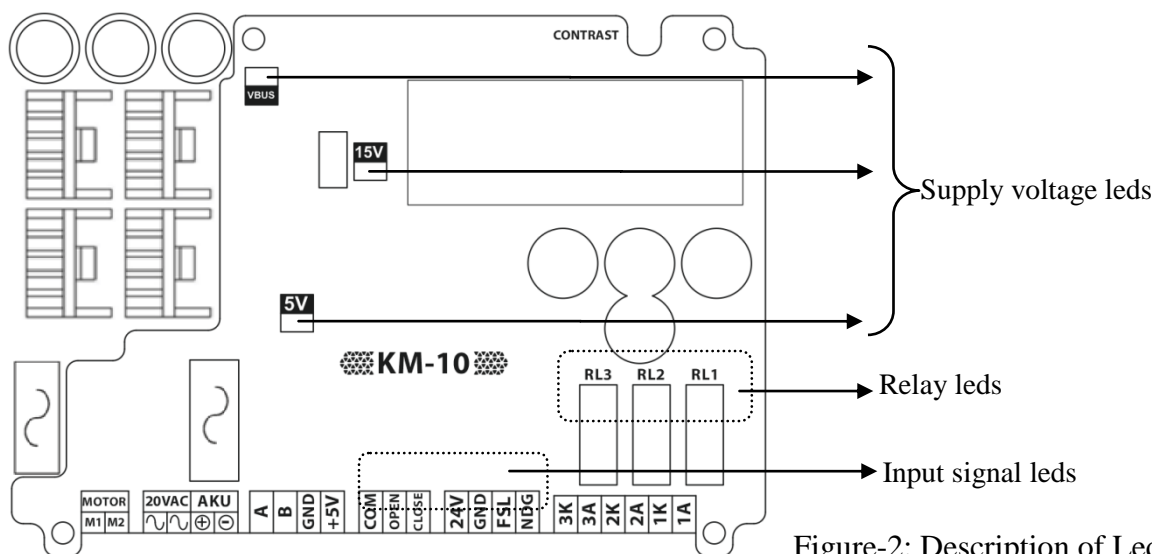

Figure-2: Description of Leds

| Supply indicators | Status | Description |
|-------------------|--------|---|
| 5V | ● ON | +5V supply is active (Supply for microcontroller and encoder) |
| | ⊗ OFF | +5V supply is inactive |
| 15V | ● ON | +15V supply is active (Supply for motor drive circuit) |
| | ⊗ OFF | +15V supply is inactive |
| 24V | ● ON | +24V supply is active (Supply for motor output, relay's coil, and control signals) |
| | ⊗ OFF | +24V supply is inactive |

| Supply indicators | Status | Description |
|-------------------|--------|-----------------------------------|
| R1 | ● ON | Doors are fully open |
| | ⊗ OFF | Doors are not fully open |
| R2 | ● ON | Doors are fully closed |
| | ⊗ OFF | Doors are not fully closed |
| R3 | ● ON | Photocell or obstruction detected |
| | ⊗ OFF | No reopening output |

| Input indicators | Status | Description |
|------------------|--------|---------------------------|
| OPEN | ● ON | Open signal is active |
| | ⊗ OFF | Open signal is inactive |
| CLOSE | ● ON | Close signal is active |
| | ⊗ OFF | Close signal is inactive |
| FSL | ● ON | Photocell is detected |
| | ⊗ OFF | Photocell is not detected |
| NDG | ● ON | Nudging mode active |
| | ⊗ OFF | Nudging mode inactive |

6 GENERAL WARNINGS

- The ac power supply voltage must be between 18V-22Vac. Supplies over 22Vac may be hazardous for the controller.
- The power of input supply transformer must be minimum 10VA more than the motor power.
- Door motor must be 24VDC reduction gear motor and maximum motor power must be 200W.
- 100-2048 pulse incremental encoders are supported. Encoder must have 2 channel output (A and B) and the operating voltage must be 5Vdc. Encoders with higher resolutions provides more accurate measurements and improves motor ascendancy.
- According to the EN81, door movement must be prevented when emergency stop, inspection or recall modes engaged. Door operation with a single command can only be used for old door units.
- According to EN 81, the maximum static closing force must not exceed 150N. Higher static closing forces may cause serious injuries.
- According to EN81, the maximum kinetic energy of the door in closing direction must not exceed 10J and for nudging closing (reduced speed closing) the maximum kinetic energy must not exceed 4J.
- The voltage applied to inputs of the door controller must not exceed 28Vdc.
- The relay output contacts of the door controller must not be used as safety circuit contact in the safety circuit of the elevator.

7 CONNECTION DIAGRAM

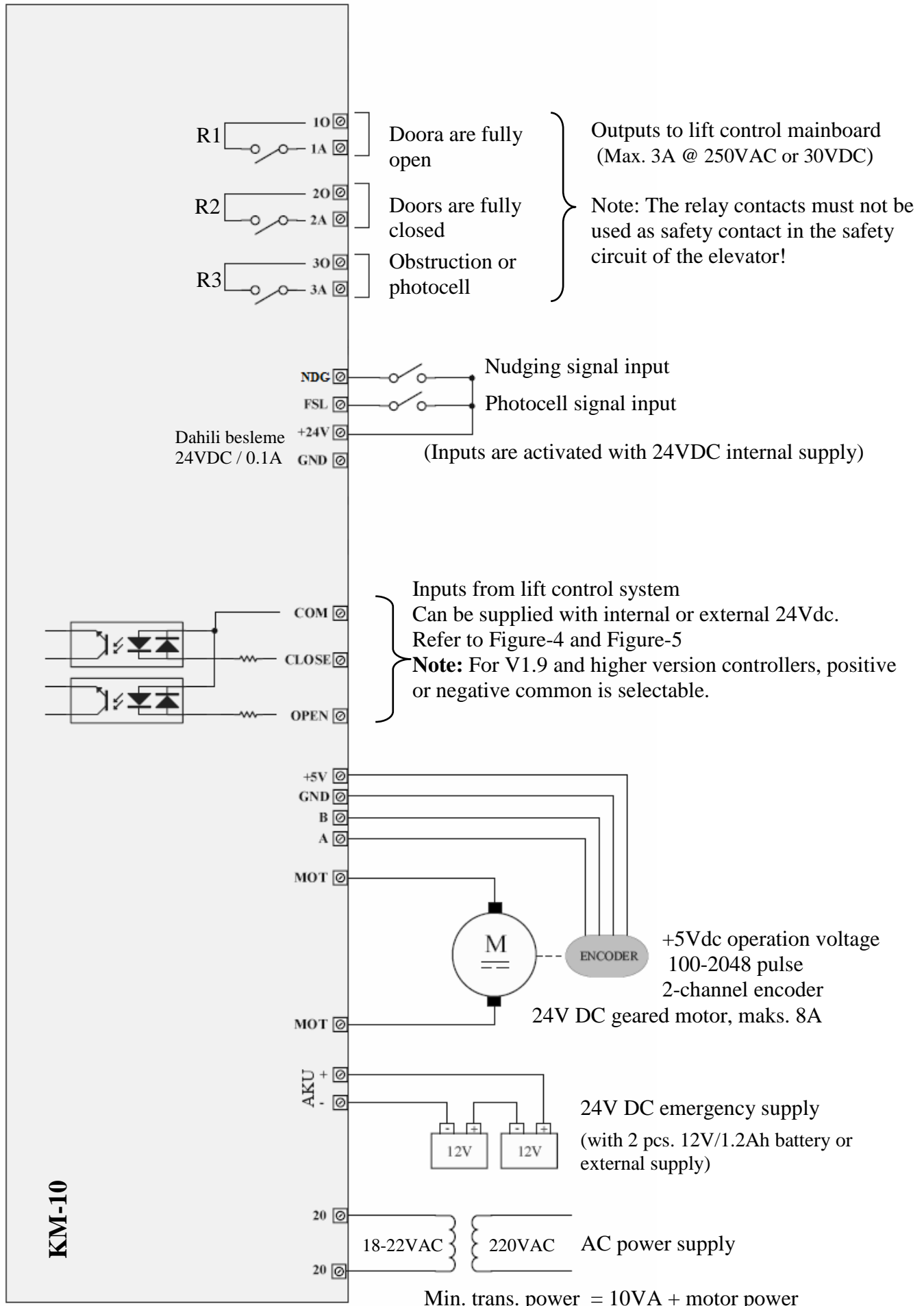

Figure-3: Connection diagram

8 CONTROL INPUTS CONNECTION

8.1 Control inputs connection with internal supply

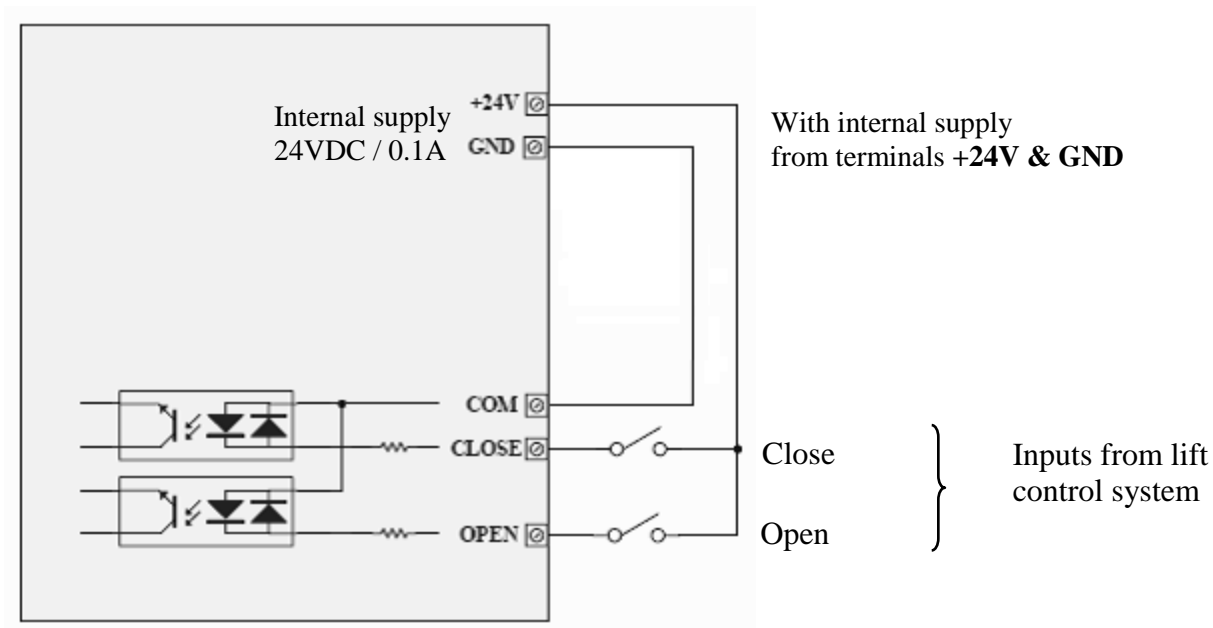

Figure-4: Control inputs connection with internal supply

8.2 Control inputs connection with external supply

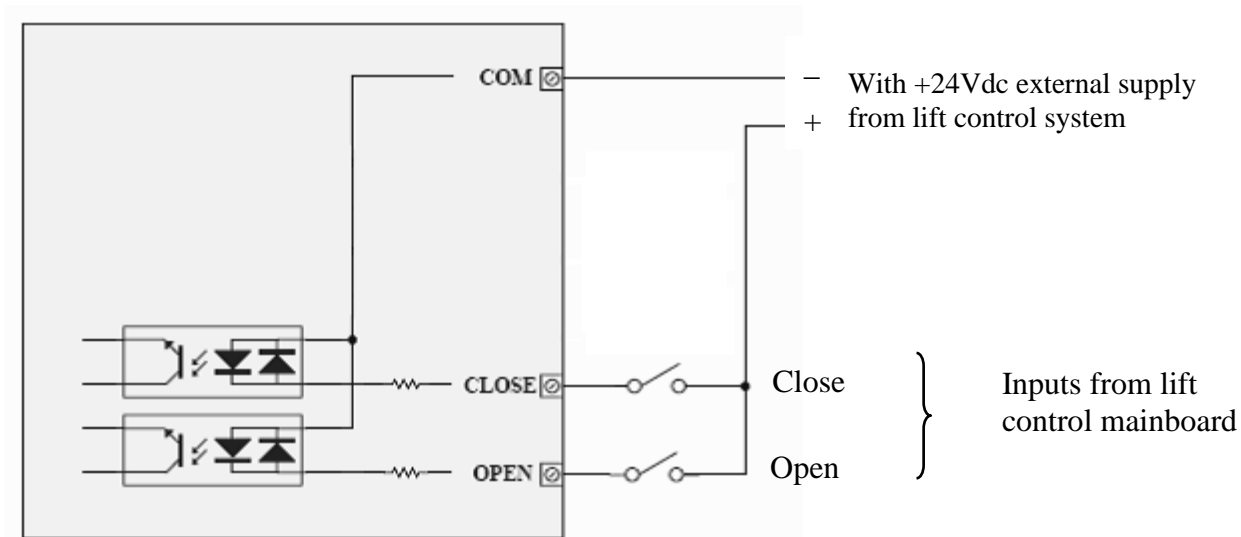

Figure-5: Control inputs connection with external supply

Note: The inputs are dual channel opto-coupled. Positive or negative common is selectable. In the sample figures above only connection with negative common is shown.

9 ONBOARD KEYPAD & DISPLAY

9.1 KEYPAD and LCD DISPLAY

KM-10 Keypad provides 2-line 16-character LCD module and 4-button keypad.

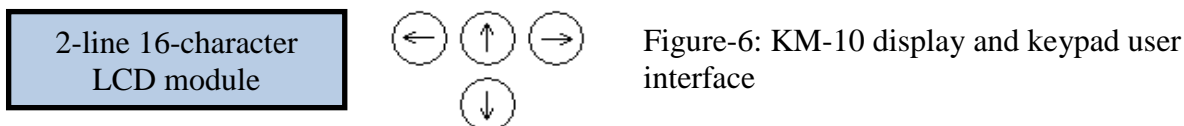

Figure-6: KM-10 display and keypad user interface

9.2 KM-10 KEYPAD FUNCTIONS

On main screen:

| | | |
|---|-------|--|
| ↑ | Up | Changes the screen |
| ↓ | Down | Door opening-closing in manual operation (Door opens if door is closed and door closes if door is open while pressing the key) |
| → | Right | Door auto-learning operation |
| ← | Left | To access menu press and hold the key for 3 seconds |

On manual operation screen:

| | |
|-----|---|
| ↑ ↓ | Changes the screen |
| ← | Door opens while holding down the key (Door opening in manual operation) |
| → | Door closes while holding down the key (Door closing in manual operation) |

Inside the menu:

| | |
|-----|-----------------------------|
| ← → | Changes the parameter |
| ↑ ↓ | Changes the parameter value |

Note: To exit menu, press the right button until the message “**EXIT FROM MENU**” will appear on the screen then press up or right button.

Note: Inside the menu, if no changes will be done in **30 seconds** controller will exit menu. The last menu changes will be saved

9.3 MONITORING & OPERATION SCREENS

KM-10 Keypad display shows a main screen (door status), control signal screen (input signals) and manual operation screen.

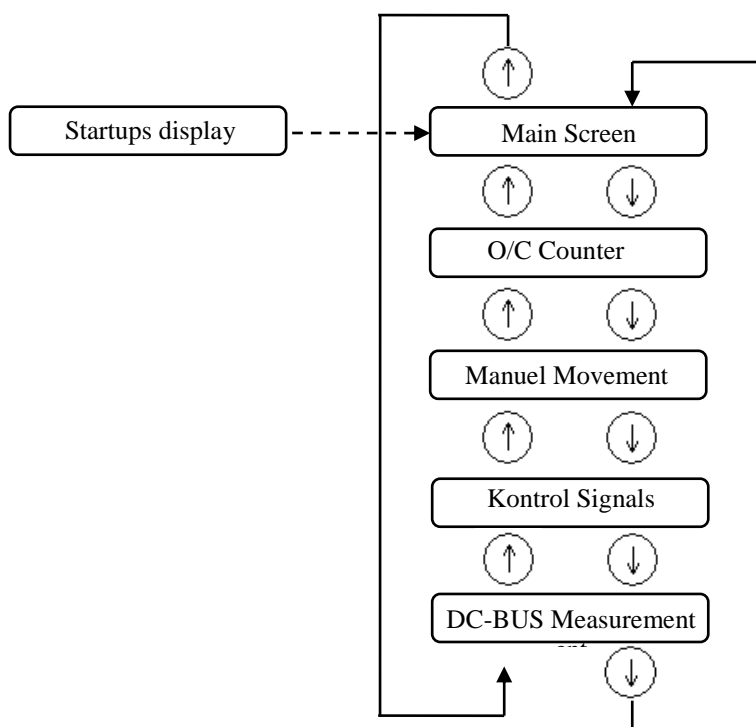

Figure-7: Screen Flows

When the power is first applied, KM-10 Keypad display shows the software version.

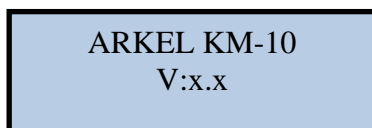

Figure-8: Start-up screen

Then the main screen is shown. In the main screen, door position, door speed and door operating status are monitored. If an error occurs it is also shown in this screen.

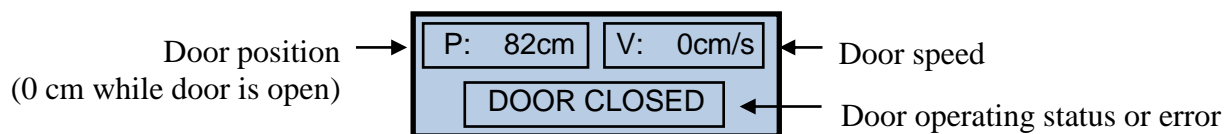

Figure-9: Main screen

On the control signals screen the status of the input signals from the lift controller opening, closing, slow closing (nudging) and high speed signals are monitored.

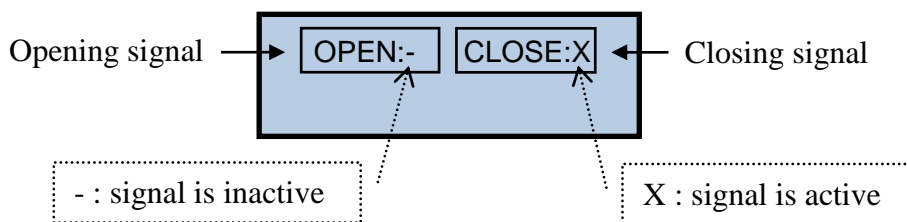

Figure-10: Control signals from the lift controller

On the manual operation screen, door can be opened and closed by the user via keypad.

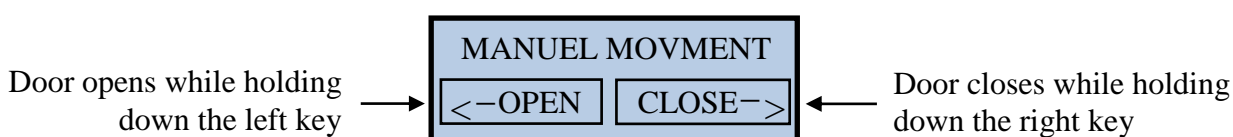

Figure-11: Manuel operation screen

Note: On this screen, the door control signals (open, signal etc.) are ignored. If no operation will be done on this screen in 60 seconds, controller will exit this screen and automatically switch back to normal operation.

The information of door opening-closing time is monitored in the counter screen.

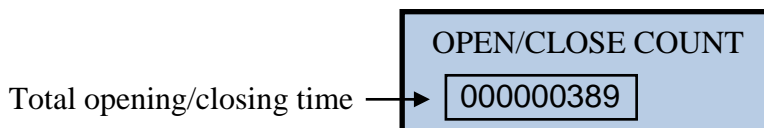

Figure-12: Counter screen

Measured DC voltage is shown on the screen in the volts unit.

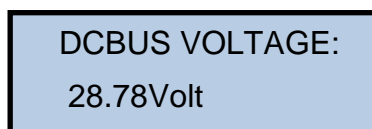

Figure-13: DC Bus voltage value

10 ACCESSING MENU

KM-10 door controller provides a parameter menu which has access levels for security, user/customer needs and easy adjustment. These access levels are limited level, basic level and manufacture level.

Accessing menu with the keypad on board is limited level. KM-10 Keypad is required for accessing menu in a basic level or in a manufacture level.

Note: Following steps should be done via KM-10 Keypad to enter menu in a manufacture level.

- De-energize KM-10.
- Energize KM-10 while pressing and holding UP and DOWN buttons together.
- KM-10 will directly enter to the advanced menu. The parameters like “ENCODER PULSE” and “GEAR RATIO” become visible and available to be changed from this menu.

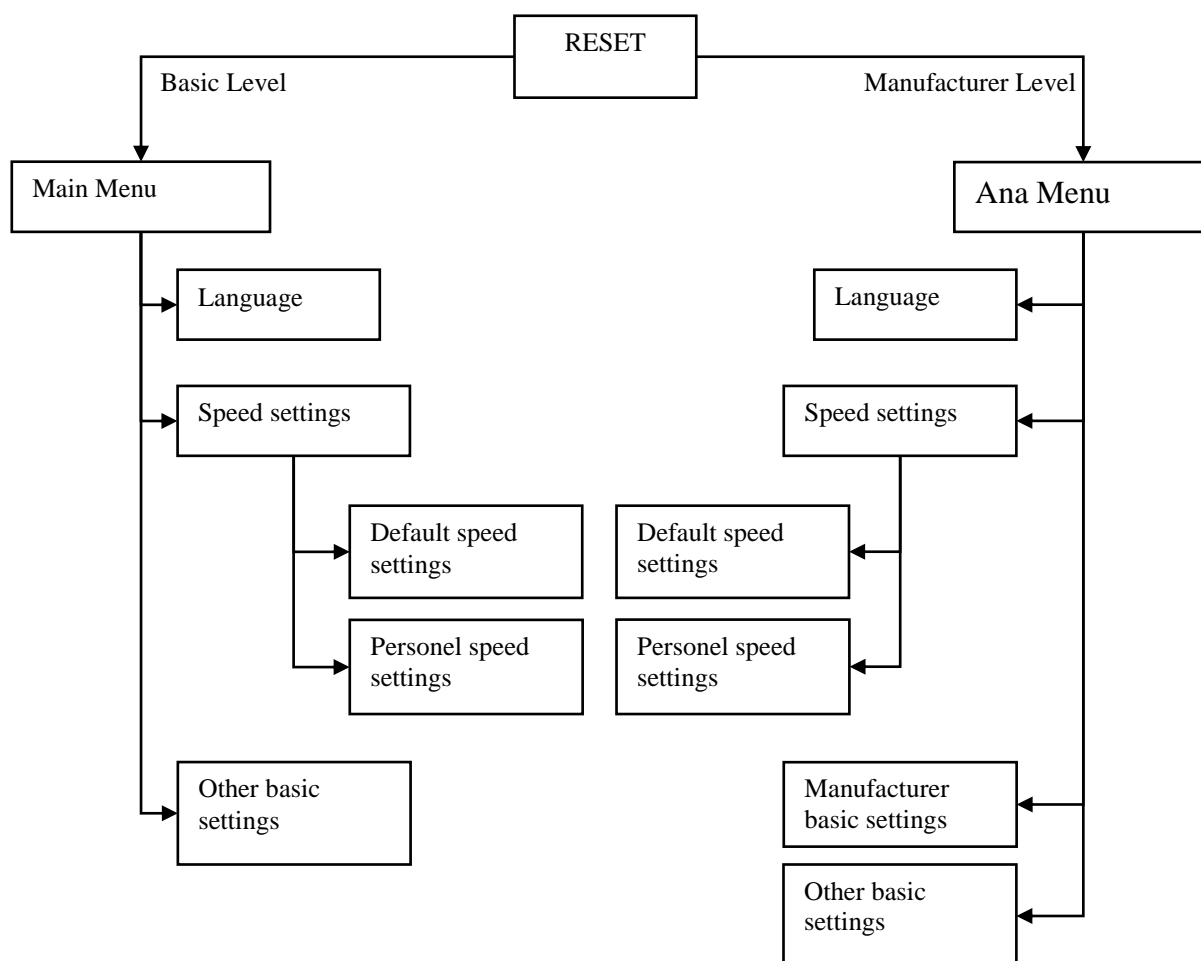

Figure-14: Menu Acces

11 PARAMETERS

| Parameter name On KM-10 Keypad display | Parameter group | Access Level |
|--|---------------------------------|---------------------|
| LANGUAGE | - | Basic |
| SPEED SETTINGS | - | Basic |
| OPENING SPEED | SPEED SETTINGS > CUSTOM SETINGS | Basic |
| OPENING SLOW SPD | SPEED SETTINGS > CUSTOM SETINGS | Basic |
| OPEN RAMP LENGHT | SPEED SETTINGS > CUSTOM SETINGS | Basic |
| OPEN SLOW AREA | SPEED SETTINGS > CUSTOM SETINGS | Basic |
| CLOSING SPEED | SPEED SETTINGS > CUSTOM SETINGS | Basic |
| CLOSING SLOW SPD | SPEED SETTINGS > CUSTOM SETINGS | Basic |
| CLS.RAMP LENGHT | SPEED SETTINGS > CUSTOM SETINGS | Basic |
| CLOSE SLOW AREA | SPEED SETTINGS > CUSTOM SETINGS | Basic |
| SKATE ZONE | - | Manufacture |
| SKATE OPEN SPEED | - | Manufacture |
| SKATE CLS. SPEED | - | Manufacture |
| OPEN HOLD FORCE | - | Manufacture |
| CLOSE HOLD FORCE | - | Manufacture |
| LEARNING SPEED | - | Manufacture |
| OBSTRUCTION PRS. | - | Limited |
| DEMO MODE | - | Limited |
| SIGNAL TYPE | - | Limited |
| ENCODER PULSE | - | Manufacture |
| SPEED CONT. KP | - | Manufacture |
| SPEED CONT. KI | - | Manufacture |
| GEAR RATIO 1 | - | Manufacture |
| GEAR RATIO 2 | - | Manufacture |
| W.CIRCUMFERENCE | - | Manufacture |
| COUNT CLEAR CODE | - | Manufacture |

12 PARAMETER SETTING via KM-10 KEYPAD

12.1 GENERAL PARAMETER SETTINGS

| | |
|----------|---------------|
| LANGUAGE | Menu language |
| TURKCE | Turkish |
| ENGLISH | English |
| Ελληνικά | Greek |

| | |
|-----------------|--|
| SPEED SETTINGS | <p>The type of door speed settings. All speed parameters can easily be set to default values or can be adjusted separately. The speed setting parameters only appear when this parameter is set to “CUSTOM SETTINGS”. Otherwise these parameters will be set to default values and will not appear in menu.</p> <p>These speed setting parameters are:</p> <ul style="list-style-type: none"> - OPENING SPEED - OPENING SLOW SPD - OPEN RAMP LENGHT - OPEN SLOW AREA - CLOSING SPEED - CLOSING SLOW SPD - CLS.RAMP LENGHT - CLOSE SLOW AREA |
| SLOW DEFAULTS | Speed setting parameters will be set to slow default values. |
| NORMAL DEFAULTS | Speed setting parameters will set to normal default values. |
| FAST DEFAULTS | Speed setting parameters will set to fast default values. |
| CUSTOM SETINGS | Each speed setting parameter can be adjusted separately. |

| | |
|-----------------|---|
| OPEN HOLD FORCE | The holding force constantly applied to motor after door fully opens to remain door open (to overcome the closing force because of the door spring) |
|-----------------|---|

| | |
|------------------|---|
| CLOSE HOLD FORCE | The holding force constantly applied to motor after door fully closes to remain door closed (to overcome the opening force because of the skate spring) |
|------------------|---|

| | |
|------------------|--|
| OBSTRUCTION PRS. | <p>The maximum opening-closing force applied to overcome an obstacle</p> <p>If an obstacle is detected in the closing operation, door stops, gives a warning to lift controller by activating the obstruction relay output (R3) and fully opens. Then obstruction relay is deactivated. After the “close signal” is given by the controller door tries to close again with normal travel speed up to the obstacle. Then it decelerates near the obstacle. If door overcomes the obstacle it continues the rest of the way at normal closing speed. This action is repeated continuously for as long as the obstacle remains.</p> <p>If an obstacle is detected in the opening operation, door stops. Obstruction relay (R3) remains deactivated. Door remains in this position and waits “close signal” from lift controller for 15 seconds. If no close signal is given after this waiting period door tries to reopen with normal travel speed up to the obstacle. Then it decelerates near the obstacle. If door overcomes the obstacle it continues the rest of the way at normal opening speed. This action is repeated continuously for as long as the obstacle remains.</p> <p>Note: According to EN81, the maximum static closing force must not exceed 150N.</p> |
|------------------|--|

| | |
|----------------|---|
| LEARNING SPEED | Door auto-learning speed during the measurement of the door travel length |
|----------------|---|

| | |
|-----------|---|
| DEMO MODE | Door test operation |
| ENABLED | Door is in test operation. Door opens and closes continuously with a few seconds intervals, The control signals (open, close etc.) will be ignored. The reopening signals (photocell or obstacle detection) are still functional. |
| DISABLED | Door is in normal operation. |

| | |
|-----------------------------|---|
| SIGNAL TYPE | The type of door control signals |
| OPEN/CLOSE SNGL. | KM-10 will be controlled by two separate inputs. 24Vdc voltage applied to terminal “Close” will cause the doors to close. And terminal “Open” will cause the door to open. If no signal is applied the door remains its position. If both inputs are applied the close signal has priority. |
| CLOSE SIGNAL | <p>KM-10 will be controlled by a single input. Only “Close” signal is used and “Open” signal is not used. 24Vdc voltage applied to terminal “Close” will cause the doors to close. Interrupting the voltage causes the door to open. During the absence of voltage the door remains open.</p> <p>Note: <i>According to the EN81 door movement must be prevented when emergency stop, inspection or recall modes engaged. This adjustment can only made for old door units.</i></p> |
| COUNT CLEAR CODE | The security code used for clearing the opening/closing counter. The count clear code (max. 4-digit) can be set by using up and down buttons. It requires to exit menu after setting the security code. If the code entered is correct, the open/close counter will be cleared after the menu is closed. |

12.2 DOOR OPENING SETTINGS

Adjust door opening settings by referring to Figure-14.

| | |
|------------------|--|
| OPENING SPEED | The maximum opening speed |
| OPENING SLOW SPD | Opening slow speed when door reaches to the opening rubber stopper |
| OPEN RAMP LENGHT | The opening distance while door accelerates (from slow speed to opening speed) and while door decelerates (from opening speed to slow speed) |
| OPEN SLOW AREA | The opening distance with slow speed up to the opening rubber stopper |
| SKATE OPEN SPEED | Skate opening speed |
| SKATE ZONE | The distance that is required for skate to fully open |

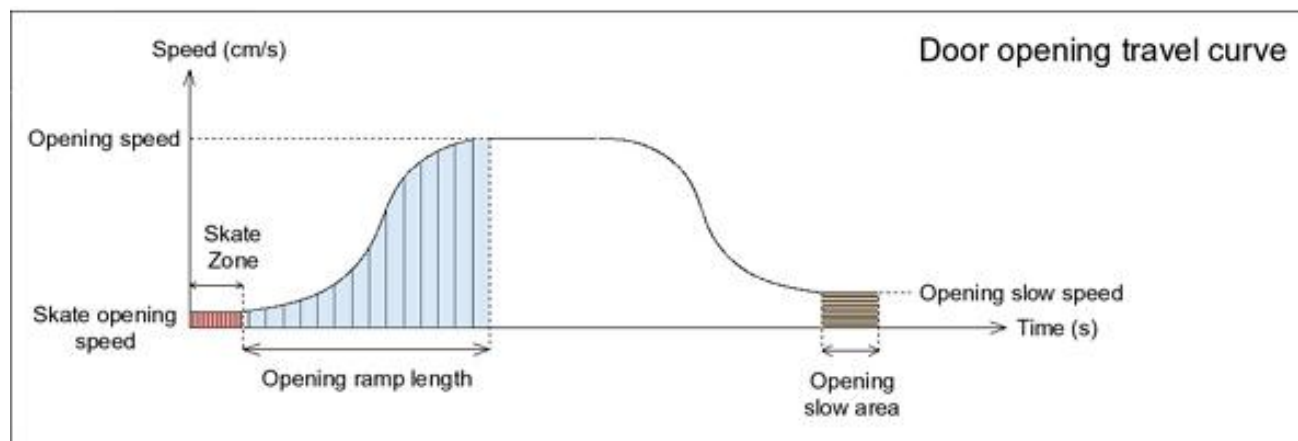

Figure-15: Door opening travel curve

12.3 DOOR CLOSING SETTINGS

Adjust door closing settings by referring to Figure-15.

| | |
|-------------------------|--|
| CLOSING SPEED | The maximum closing speed |
| CLOSING SLOW SPD | Closing slow speed when door reaches to the closing rubber stopper |
| CLS.RAMP LENGHT | The closing distance while door accelerates (from slow speed to closing speed) and while door decelerates (from closing speed to slow speed) |
| CLOSE SLOW AREA | The closing distance with slow speed up to the closing rubber stopper |
| SKATE CLS. SPEED | Skate closing speed |
| SKATE ZONE | The distance that is required for skate to fully closed |

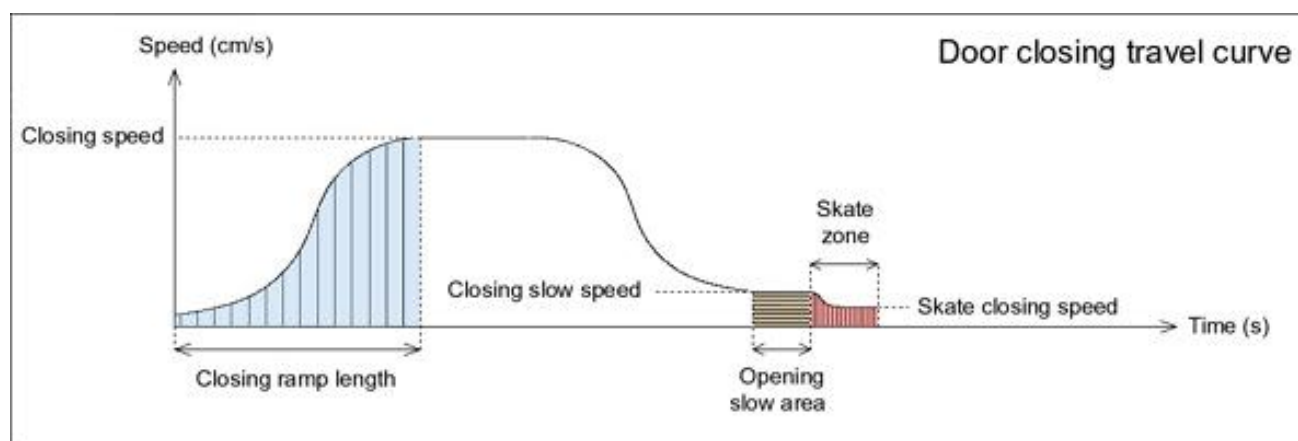

Figure-16: Door closing travel curve

MAX. DOOR CLOSING SPEED

According to EN81, the maximum kinetic energy of the door in the closing direction must not exceed 10J. And for nudging closing (reduced speed closing) the max. kinetic energy must not exceed 4J. This can be calculated by the formula:

$$\text{Maximum kinetic energy} = (1/2) \times K_m \times (V_{\text{max}}^2)$$

K_m : Total door panel weight (kg)

V_{max} : Maximum speed of the door (m/s)

An example for a calculation of maximum speed:

$K_m = 120 \text{ kg}$

The maximum closing speed $V_{\text{max}}(\text{normal}) = 0,4 \text{ m/s}$

The maximum nudging speed $V_{\text{max}}(\text{nudging}) = 0,25 \text{ m/s}$

12.4 MOTOR SETTINGS

| | |
|-----------------|---|
| ENCODER PULSE | The pulse of the encoder per revolution |
| GEAR RATIO 1 | Motor speed in rpm |
| GEAR RATIO 2 | Reduction output speed in rmp (Motor speed / Reduction Ratio) |
| W.CIRCUMFERENCE | Door wheel circumference |

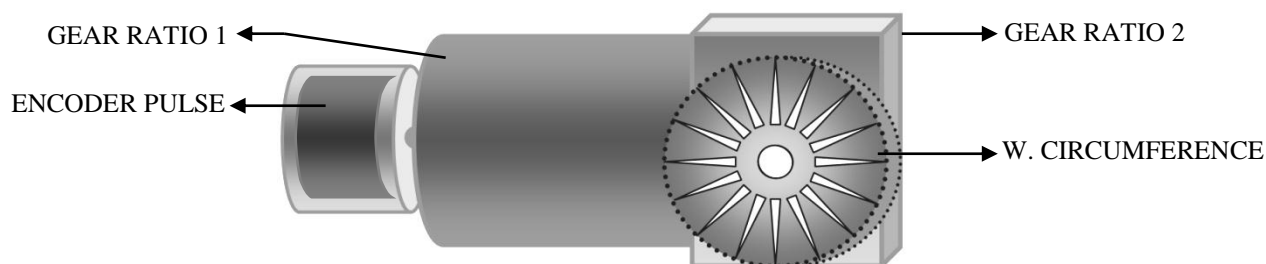
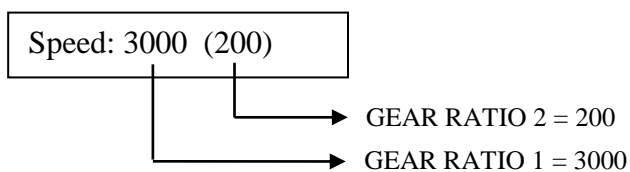

Figure-17: Motor settings

Samples to determine motor gear ratio from motor name plate are shown below:

Sample motor name plate 1:



Sample motor name plate 2:

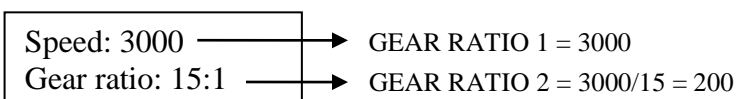

12.5 PI SPEED REGULATOR ADJUSTMENT

| | |
|----------------|---|
| SPEED CONT. KP | The differential factor of PI speed regulator |
|----------------|---|

| | |
|----------------|---|
| SPEED CONT. KI | The integral factor of PI speed regulator |
|----------------|---|

“SPEED CONT. KP” and “SPEED CONT. KI” parameters determine the PI speed regulator’s reaction sensitivity which adjusts the motor speed.

The integral factor KI multiplies the total of errors so must be adjusted to very smaller than KP otherwise it causes vibration and overshoots at travel curve. Usually it is better to adjust $KP > 10 \times KI$.

If KI and KP are too high it makes noise at motor. Too small values cause delays to catch the reference speed and sensitivity loss.

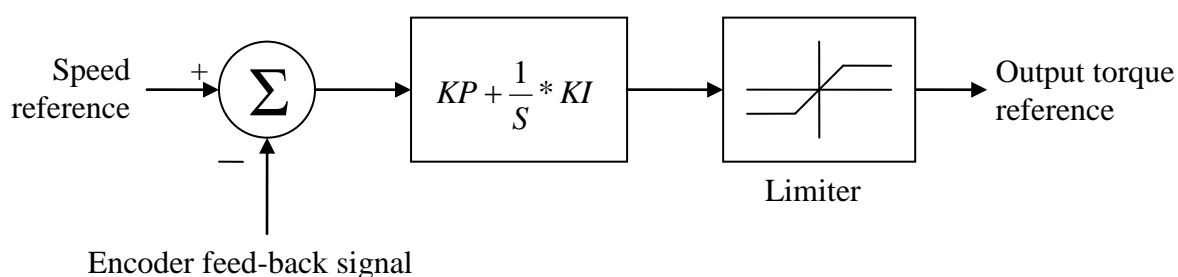

Figure-18: PI speed regulator adjustment

13 EMERGENCY OPERATION

- For emergency operation, serially connected two 12V battery (dry-acid) can be connected to the AKU+ and AKU- terminals. In normal operation the batteries will be kept as charged. If the power supply energy cut off, the KM10 will continue to its normal operation. However if the batteries discharge operation will be stop. This is a point should be taken into account while installation.

14 NUDGING OPERATION

If NDG signal is active (in a fire alarm state), nudging operation is activated. In this operation door should be closed as soon as possible. To prevent injury of people who can be present between the doors, doors are tried to close very slowly even the FSL signal is broken. While this operation audible alarm is generated.

16 STATUS MESSAGES

KM-10 KEYPAD displays the status of door operation. Below these messages are listed:

| Status message | Description |
|----------------|---|
| DOOR OPENED | Door is fully open. The door position data P: 0cm. |
| DOOR CLOSED | Door is fully closed. The door position data P will be the door length. |
| DOOR OPENING | Door is opening. The door opening speed and door position data is shown on display. |
| DOOR CLOSING | Door is closing. The door closing speed and door position data is shown on display. |

17 ERROR MESSAGES

The error messages of KM-10 door controller which are shown either on KM-10 Keypad display or onboard digital display are listed below:

| KM-10 Keypad LCD module | Description | Reason |
|--------------------------------|----------------------------------|---|
| CLS. OBSTRUCTION | Obstacle detected during closing | <ul style="list-style-type: none"> * Door mechanically blocked * Obstruction pressure value is too low * Encoder is faulty * Ac power supply is too low |
| OPEN OBSTRUCTION | Obstacle detected during opening | <ul style="list-style-type: none"> * Door mechanically blocked * Obstruction pressure value is too low * Encoder is faulty * Ac power supply is too low |

18 TROUBLESHOOTING

DOOR DOES NOT MOVE

- Check the power led 24V on the board. If 24V led is OFF check the ac power supply and the ac supply fuse on the left side of the board.
- Check the motor power connection on terminals MOT.
- Check the parameter “SIGNAL TYPE” (parameter Π3 on digital display). When this parameter is set to “OPEN/CLOSE SNGL.” door will not move until a command is given from terminals OPEN or CLOSE. Check these input leds. In order to test these inputs, disconnect the wiring of OPEN and CLOSE terminals. Then test these inputs by making a bridge between terminals: GND > COM, 24V > OPEN and 24V > CLOSE.
- Check that door is not mechanically blocked

DOOR PANELS ARE OPENING-CLOSING RAPIDLY AND UNCONTROLLABLY

- Check motor and encoder wirings. When you move the door manually the speed of door must be shown on display.
- Encoder channel-A and channel-B connection may be wrong. Interchange these inputs.

DOOR DOES NOT OPEN

- When door open signal is activated OPEN led on board must be ON. If OPEN led is OFF be sure that lift controller gives open command.
- Check that the CLOSE led is OFF. If close signal is active door does not open because close signal has priority.
- If the parameter “SIGNAL TYPE” (parameter Π3 on digital display) is set to “CLOSE SIGNAL” check that close signal is not active.
- Check that door is not mechanically blocked.

DOOR DOES NOT CLOSE

- When door close signal is activated CLOSE led on board must be ON. If CLOSE led is OFF be sure that lift controller gives close command.
- Check that door is not mechanically blocked.

DOOR MOVES IN REVERSE DIRECTION

- Door connection may be wrong. Interchange the motor power outputs and at the same time interchange the encoder channels A and B.

DOOR HITS or DOOR DECELERATES EARLY

- Be sure that the auto-learning operation is done properly
- Check that door speed setting are adjusted correctly

DOOR OFTEN DETECTS OBSTACLE

- Check that door has no mechanical defect.
- Check that obstruction pressure is not too low.
- Check that encoder is not faulty.
- Check that Ac power supply is not too low

DOOR PANELS ARE VIBRATING

- Check that the encoder is connected correctly.
- Check the PI speed regulator settings (SPEED CONT. KP and SPEED CONT. KI)
- Check that door has no mechanical defect.

DOOR FULLY OPENS THEN IT MOVES 1-2cm BACK AND TRIES TO OPEN AGAIN

- Door open hold force may be too low and door cannot overcome the closing force because of the door spring.
- At that floor, landing door spring may be too strong.

DOOR MOTOR and DRIVE CIRCUIT IS HEATING UP EVEN DOOR STOPS

- Check that the opening and closing hold force are not too high.

19 DIMENSIONS

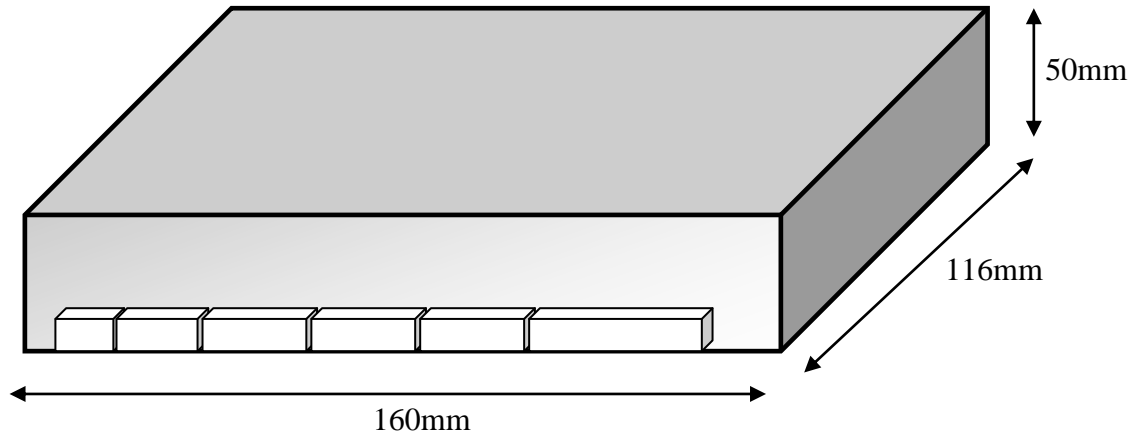
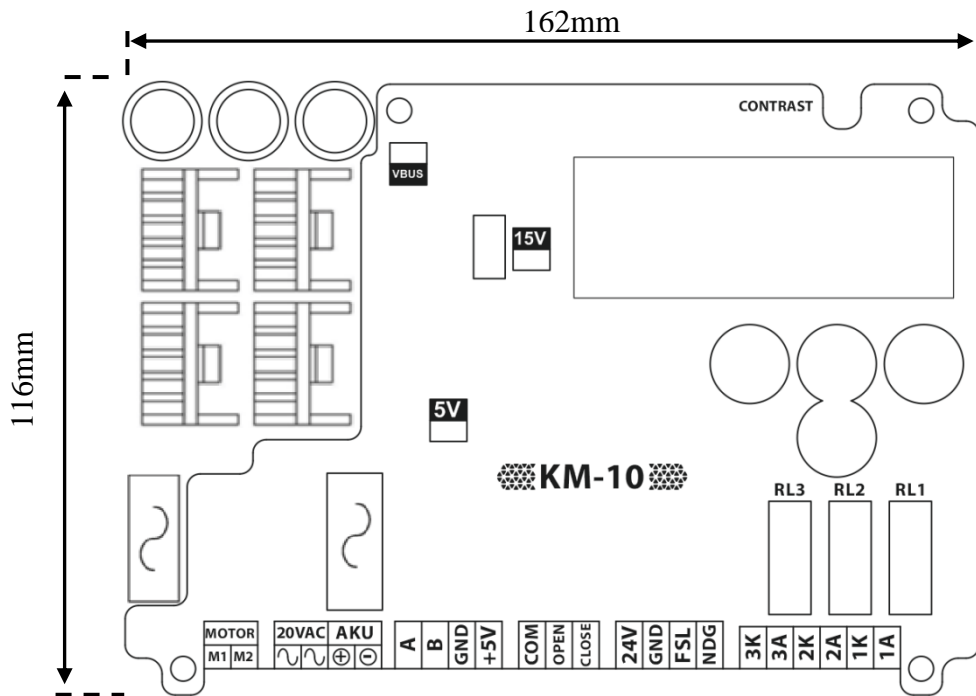

Figure-19: Front-right side view



Mounting holes : Ø4mm

Figure-20: Front view

ARKEL Elektrik Elektronik Ticaret Ltd. Şti.

Şerifali Mah. Bayraktar Bulvarı Şehit Sok. No:32 Umraniye İstanbul TURKIYE

Tel: (+90 216) 540 67 24

Fax: (+90 216) 540 03 09

E-mail: info@arkel.com.tr

www.arkel.com.tr