

Hydra PLUS

SPARE PARTS

PEZZI DI RICAMBIO

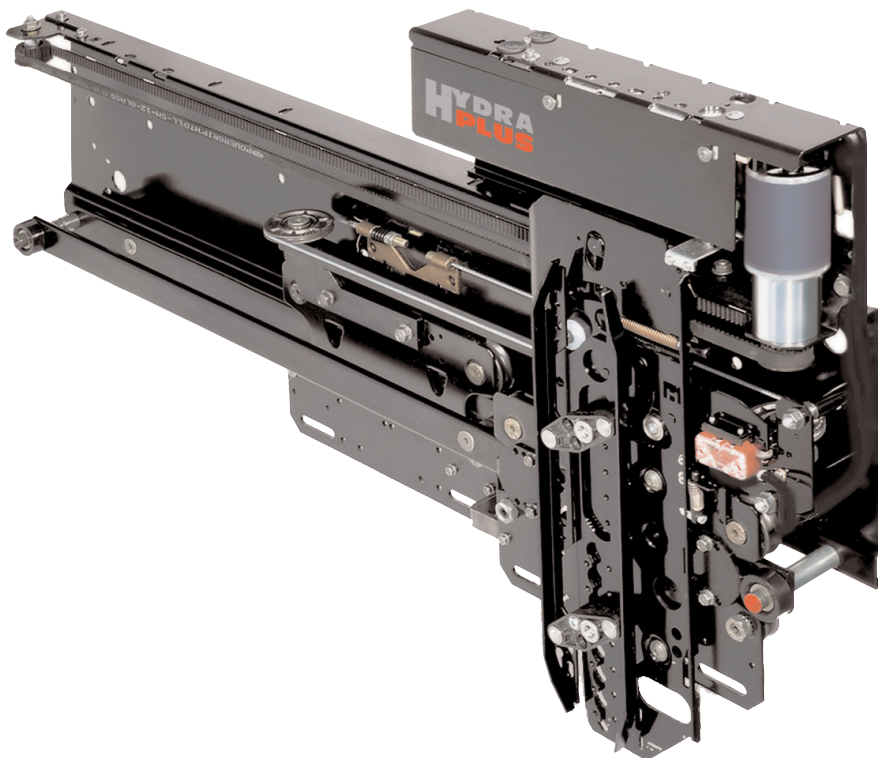

C	Updated Lay-out and code of pages 33, 34, 35. Added code of page 37	19/02/08
	<i>Aggiornato Lay-out e codice a pag. 33, 34, 35. Aggiunto codice a pag. 37</i>	
B	Updated Lay-out and code of pages 33, 34, 35	12/07/07
	<i>Aggiornato Lay-out e codice a pag. 33, 34, 35</i>	
A	General up-dating	16/05/07
	<i>Aggiornamento generale</i>	
MOD.	DESIGNATION	DATE

INDEX - INDICE

Description Descrizione	page pagina
TWO PANELS CENTRAL OPENING CAR DOOR TYPE 02/C	3
PORTA DI CABINA DUE ANTE OPPOSTE, TIPO 02/C	3
TWO PANELS TELESCOPIC CAR DOOR TYPE 12/R-L	5
PORTA DI CABINA TELESCOPICA DUE ANTE, TIPO 12/R-L.....	5
THREE PANELS TELESCOPIC CAR DOOR TYPE 32/R-L	7
PORTA DI CABINA TELESCOPICA TRE ANTE, TIPO 32/R-L	7
THREE PANELS TELESCOPIC CAR DOOR TYPE 35/R-L	9
PORTA DI CABINA TELESCOPICA TRE ANTE, TIPO 35/R-L	9
FOUR PANELS CENTRAL OPENING CAR DOOR TYPE 42/C	11
PORTA DI CABINA QUATTRO ANTE OPPOSTE, TIPO 42/C	11
SIX PANELS CENTRAL OPENING CAR DOOR TYPE 62/C	13
PORTA DI CABINA SEI ANTE OPPOSTE, TIPO 62/C	13
FOUR PANELS CENTRAL OPENING CAR DOOR TYPE 44/R	15
PORTA DI CABINA QUATTRO ANTE OPPOSTE, TIPO 44/R.....	15
SIX PANELS CENTRAL OPENING CAR DOOR TYPE 66/R	17
PORTA DI CABINA SEI ANTE OPPOSTE, TIPO 66/R	17
ONE PANEL CAR DOOR TYPE 72/R-L	19
PORTA DI CABINA UN'ANTA, TIPO 72/R-L.....	19
ECO HYDRA PLUS COUPLERS TYPE 02/C - 44/R - 66/R	21
ABBINAMENTI ECO HYDRA PLUS, TIPO 02/C - 44/R - 66/R.....	21
MIDI SUPRA COUPLERS TYPE 02/C - 44/R - 66/R	22
ABBINAMENTI MIDI SUPRA, TIPO 02/C - 44/R - 66/R	22
MIDI SUPRA 42 - 62 COUPLERS TYPE 42/C - 62/C	23
ABBINAMENTI MIDI SUPRA 42 - 62, TIPO 42/C - 62/C	23
ECO HYDRA PLUS COUPLERS TYPE 12/R-L - 32-35/R-L - 72/R-L	24
ABBINAMENTI ECO HYDRA PLUS, TIPO 12/R-L - 32-35/R-L - 72/R-L	24
MIDI SUPRA COUPLERS TYPE 12/R-L - 32/R-L	25
ABBINAMENTI MIDI SUPRA, TIPO 12/R-L - 32/R-L.....	25
MIDI SUPRA COUPLERS TYPE 35/R-L - 72/R-L	26
ABBINAMENTI MIDI SUPRA, TIPO 35/R-L - 72/R-L.....	26
ECO HYDRA PLUS COUPLERS WITH CAR DOOR LOCK TYPE 02/C - 44/R - 66/R	27
ABBINAMENTI CON BLOCCAGGIO FUORI PIANO ECO HYDRA PLUS, TIPO 02/C - 44/R - 66/R	27
MIDI SUPRA COUPLERS WITH CAR DOOR LOCK TYPE 02/C - 44/R - 66/R	28
ABBINAMENTI CON BLOCCAGGIO FUORI PIANO MIDI SUPRA, TIPO 02/C - 44/R - 66/R.....	28
MIDI SUPRA 42 - 62 COUPLERS WITH CAR DOOR LOCK TYPE 42/C - 62/C	29
ABBINAMENTI CON BLOCCAGGIO FUORI PIANO MIDI SUPRA 42 - 62, TIPO 42/C - 62/C.....	29
ECO HYDRA PLUS COUPLERS WITH CAR DOOR LOCK TYPE 12/R-L - 32-35/R-L - 72/R-L	30
ABBINAMENTI CON BLOCCAGGIO FUORI PIANO ECO HYDRA PLUS, TIPO 12/R-L - 32-35/R-L - 72/R-L	30
MIDI SUPRA COUPLERS WITH CAR DOOR LOCK TYPE 12/R-L - 32/R-L	31
ABBINAMENTI CON BLOCCAGGIO FUORI PIANO MIDI SUPRA, TIPO 12/R-L - 32/R-L	31
MIDI SUPRA COUPLERS WITH CAR DOOR LOCK TYPE 35/R-L - 72/R-L	32
ABBINAMENTI CON BLOCCAGGIO FUORI PIANO MIDI SUPRA, TIPO 35/R-L - 72/R-L.....	32

OPTIONALS WITH CAR DOOR LOCK TYPE 02/C - 44/R - 66/R.....	33
ACCESSORI CON BLOCCAGGIO FUORI PIANO, TIPO 02/C - 44/R - 66/R	33
OPTIONALS WITH CAR DOOR LOCK TYPE 42/C - 62/C	34
ACCESSORI CON BLOCCAGGIO FUORI PIANO, TIPO 42/C - 62/C.....	34
OPTIONALS WITH CAR DOOR LOCK TYPE 12/R-L - 32-35/R-L - 72/R-L	35
ACCESSORI CON BLOCCAGGIO FUORI PIANO, TIPO 12/R-L - 32-35/R-L - 72/R-L	35
ALUMINIUM SILL.....	36
SOGLIE IN ALLUMINIO	36
SPARE PARTS FOR TOWED CABLE	37
RICAMBI FUNI	37
MECHANICAL RELEASE TYPE 1118 - SIDE OPENING CAR DOORS.....	38
SBLOCCO MECCANICO TIPO 1118 - PORTE DI CABINA AD APERTURA LATERALE	38
MECHANICAL RELEASE TYPE 1119 - CENTRE OPENING CAR DOORS.....	39
SBLOCCO MECCANICO TIPO 1119 - PORTE DI CABINA AD APERTURA CENTRALE.....	39
MECHANICAL RELEASE TYPE 1200 FOR CAR DOORS.....	40
SBLOCCO MECCANICO TIPO 1200 PER PORTE DI CABINA.....	40
MECHANICAL RELEASE TYPE 1201 FOR CAR DOORS.....	41
SBLOCCO MECCANICO TIPO 1201 PER PORTE DI CABINA	41
MECHANICAL RELEASE TYPE 1202 FOR CAR DOORS.....	42
SBLOCCO MECCANICO TIPO 1202 PER PORTE DI CABINA.....	42
CABLE CHAIN ASSEMBLY FOR CENTRAL OPENING DOORS.....	43
MONTAGGIO GUIDACAVI PER PORTE AD APERTURA CENTRALE.....	43
CABLE CHAIN ASSEMBLY FOR SIDE OPENING DOORS.....	44
MONTAGGIO GUIDACAVI PER PORTE AD APERTURA LATERALE	44
LSE EDGE ASSEMBLY FOR SIDE OPENING DOORS.....	45
MONTAGGIO COSTOLA LSE PER PORTE AD APERTURA LATERALE	45
LSE EDGE ASSEMBLY FOR CENTRAL OPENING DOORS	46
MONTAGGIO COSTOLA LSE PER PORTE AD APERTURA CENTRALE	46

02/C

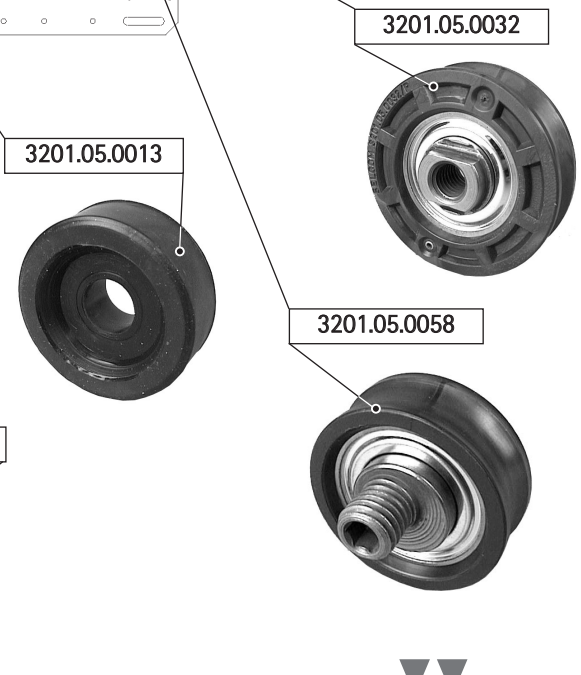
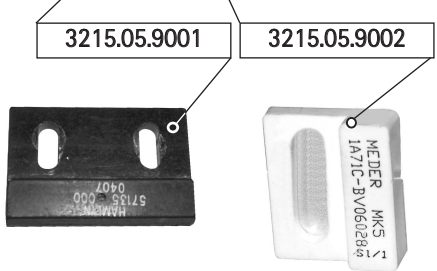
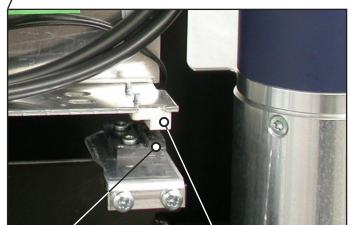
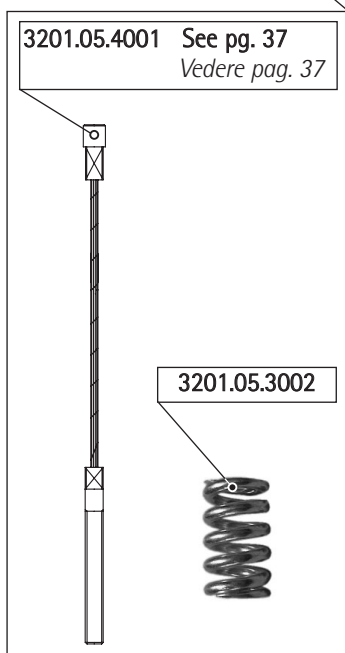
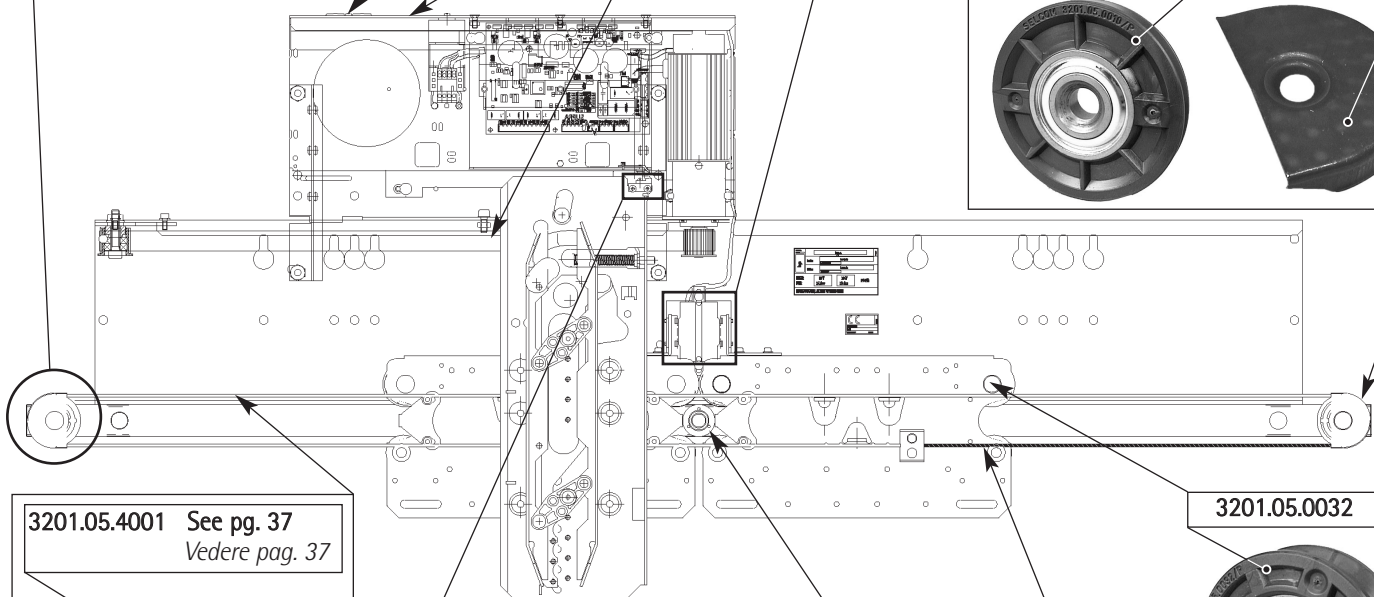
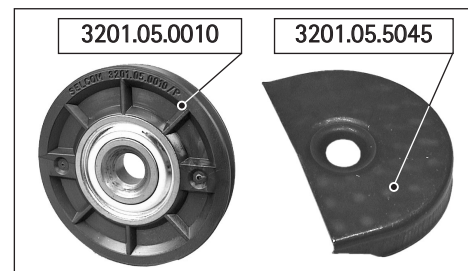
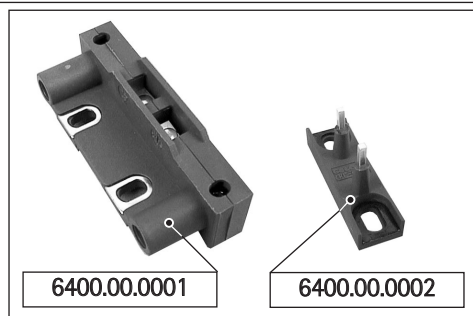
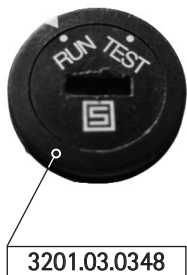
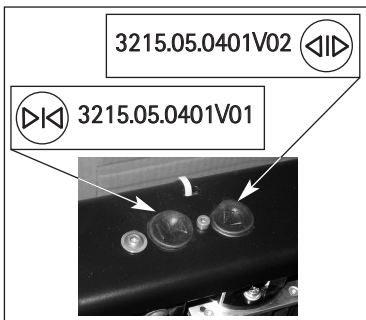
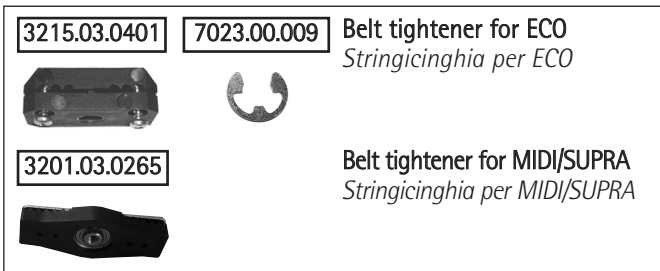
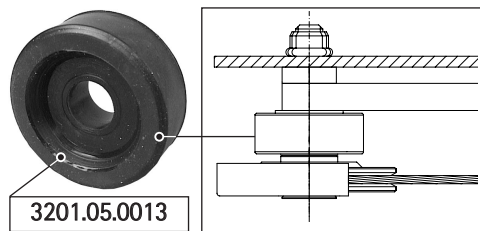

3201.33.0009 ed.C / 4-46

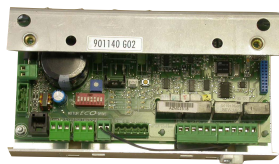

3215.15.7400 ECO board
Quadro ECO

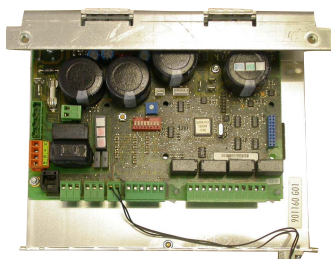

3201.03.0262 MIDI/SUPRA board
Quadro MIDI/SUPRA

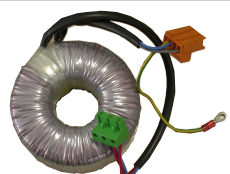

3215.02.0852V02 ECO Transformer
Trasformatore ECO
(127÷230V)



3201.03.0263 MIDI/SUPRA Transformer
Trasformatore MIDI/SUPRA
(127÷230V)

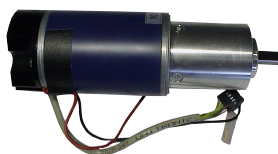

3215.03.0850 ECO Motor
Motore ECO

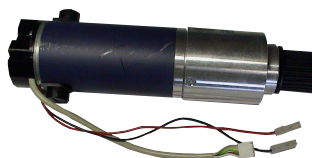

3201.04.0901V01 MIDI Motor
Motore MIDI

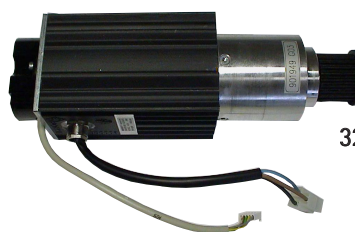

3201.04.0900V01 SUPRA Motor
Motore SUPRA

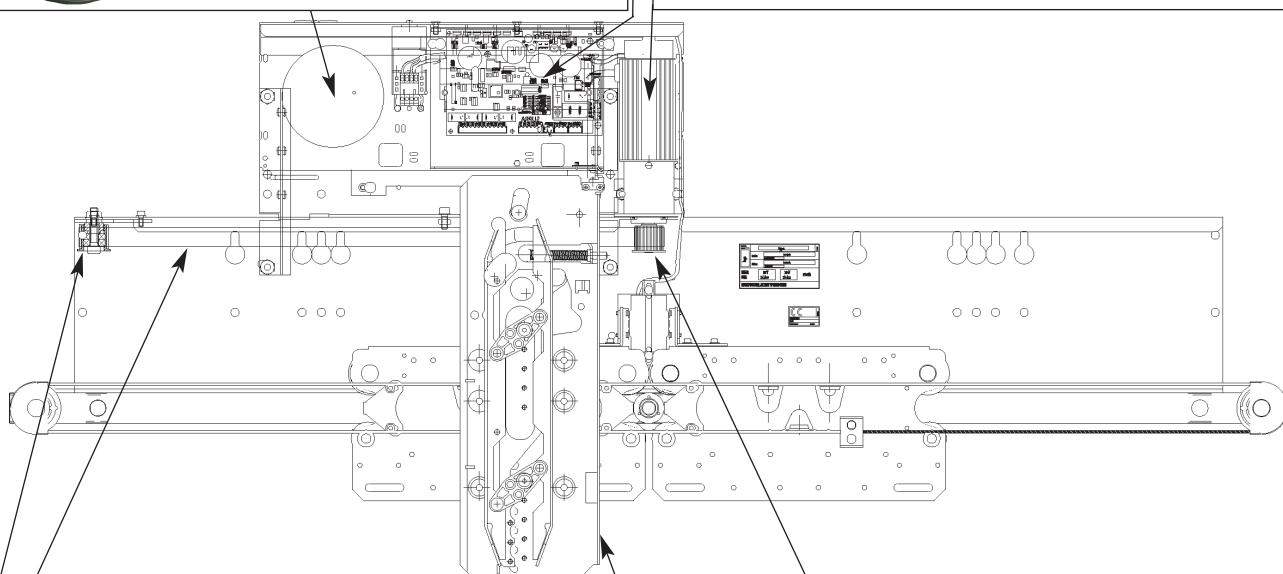

3215.05.7400 Belt for ECO door
Cinghia per porta ECO
3201.05.7315 Belt for MIDI/SUPRA door
Cinghia per porta MIDI/SUPRA

Specify door type and C.O.
Specificare il tipo porta e il P.L.

See pg. 24-25
Vedere pag. 24-25

3215.05.0041 Motor pulley for ECO
Puleggia motore per ECO

3201.05.0096 Motor pulley for MIDI/SUPRA
Puleggia motore per MIDI/SUPRA

7024.00.010

3215.04.0400 Idle pulley for ECO
Puleggia folle per ECO

3201.03.0266 Idle pulley for MIDI/SUPRA
Puleggia folle per MIDI/SUPRA





3215.03.0850 ECO Motor
Motore ECO



3201.04.0901V01 MIDI Motor
Motore MIDI



3201.04.0900V01 SUPRA Motor
Motore SUPRA

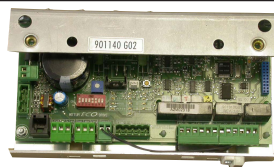

3215.15.7400 ECO board
Quadro ECO

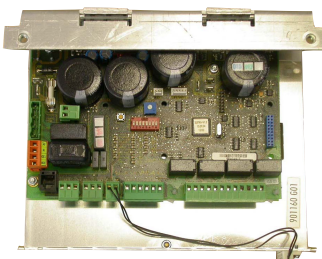

3201.03.0262 MIDI/SUPRA board
Quadro MIDI/SUPRA

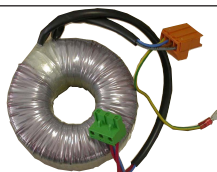

3215.02.0852V02 ECO Transformer
Trasformatore ECO
(127÷230V)

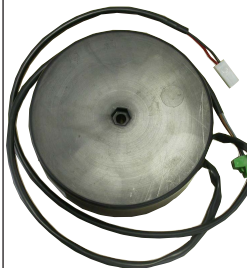

3201.03.0263 MIDI/SUPRA Transformer
Trasformatore MIDI/SUPRA
(127÷230V)

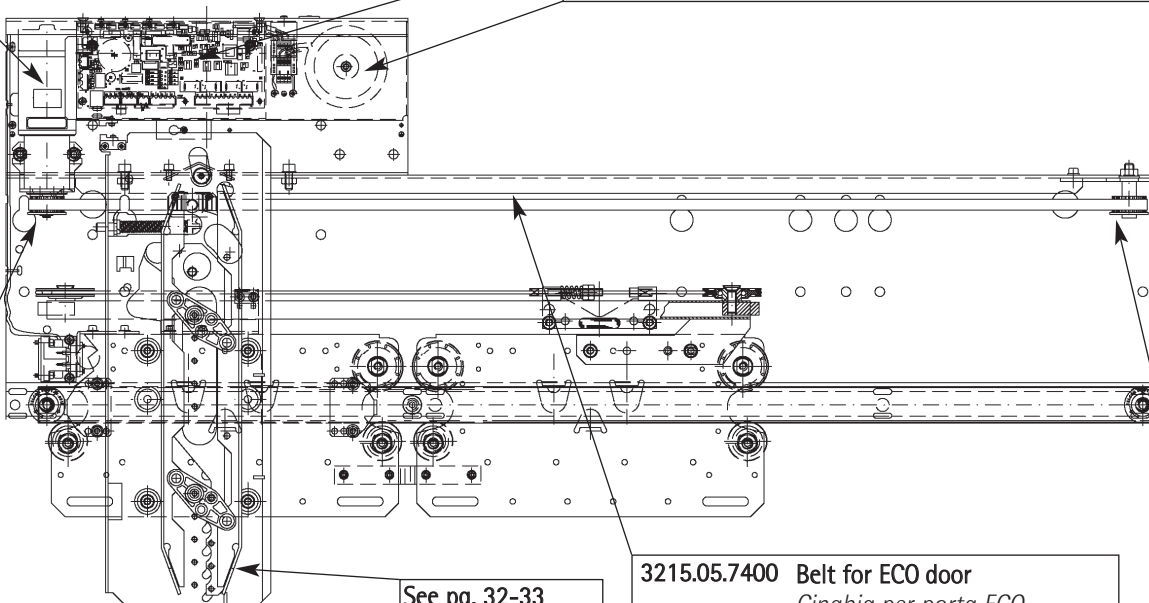

3215.05.0041 Motor pulley for ECO
Puleggia motore per ECO

3201.05.0096 Motor pulley for MIDI/SUPRA
Puleggia motore per MIDI/SUPRA

7024.00.010



See pg. 32-33
Vedere pag. 32-33

3215.05.7400 Belt for ECO door
Cinghia per porta ECO

3201.05.7315 Belt for MIDI/SUPRA door
Cinghia per porta MIDI/SUPRA

Specify door type and C.O.
Specificare il tipo porta e il P.L.

3215.04.0400 Idle pulley for ECO
Puleggia folle per ECO

3201.03.0266 Idle pulley for MIDI/SUPRA
Puleggia folle per MIDI/SUPRA



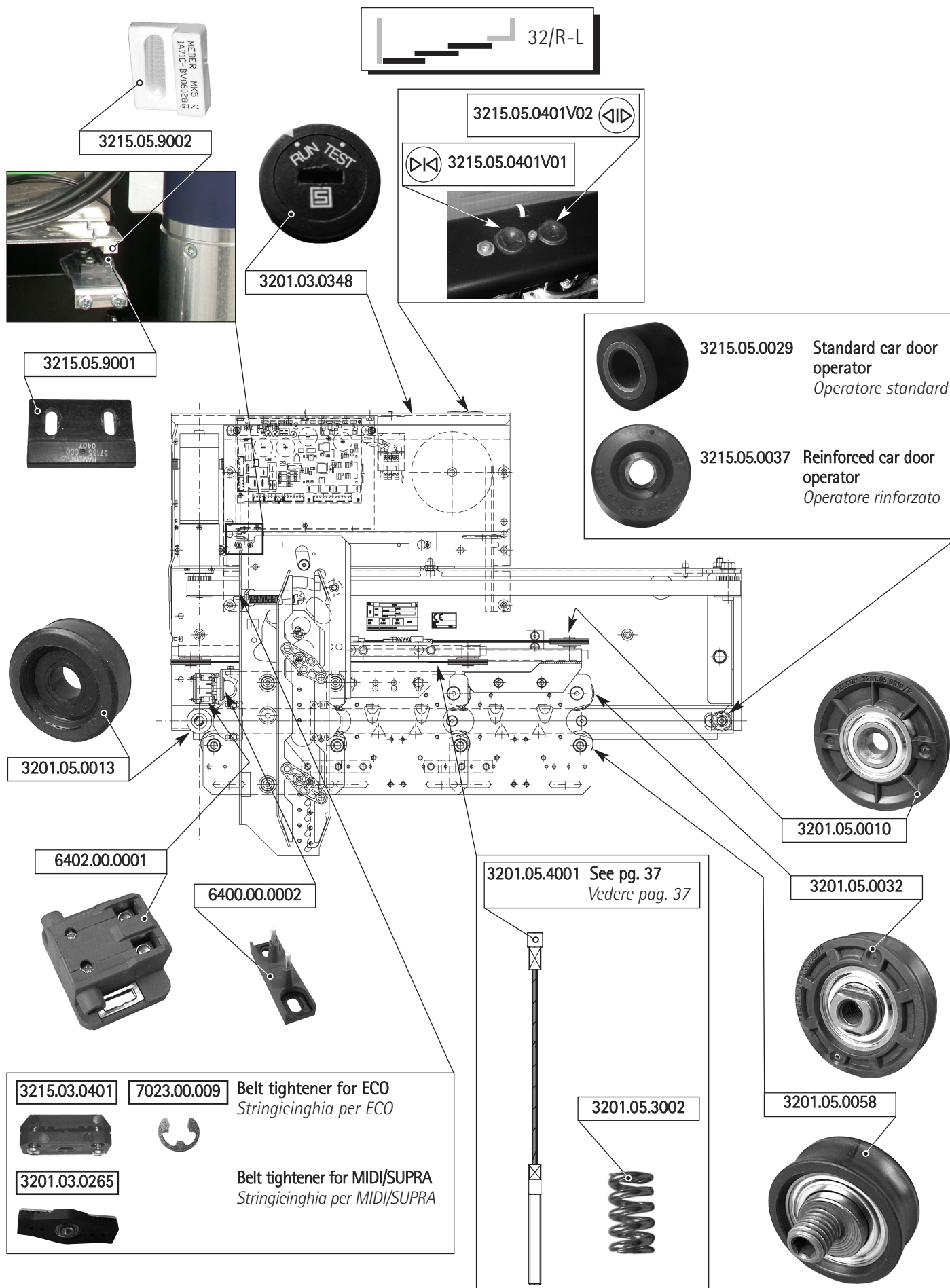



3215.03.0850 ECO Motor
Motore ECO



3201.04.0901V01 MIDI Motor
Motore MIDI



3201.04.0900V01 SUPRA Motor
Motore SUPRA

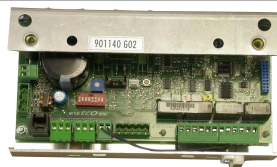

3215.15.7400 ECO board
Quadro ECO

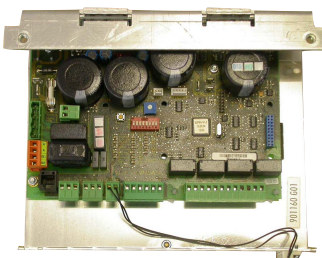

3201.03.0262 MIDI/SUPRA board
Quadro MIDI/SUPRA

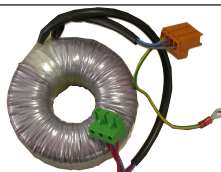

3215.02.0852V02 ECO Transformer
Trasformatore ECO
(127÷230V)

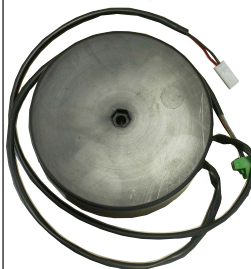

3201.03.0263 MIDI/SUPRA Transformer
Trasformatore MIDI/SUPRA
(127÷230V)

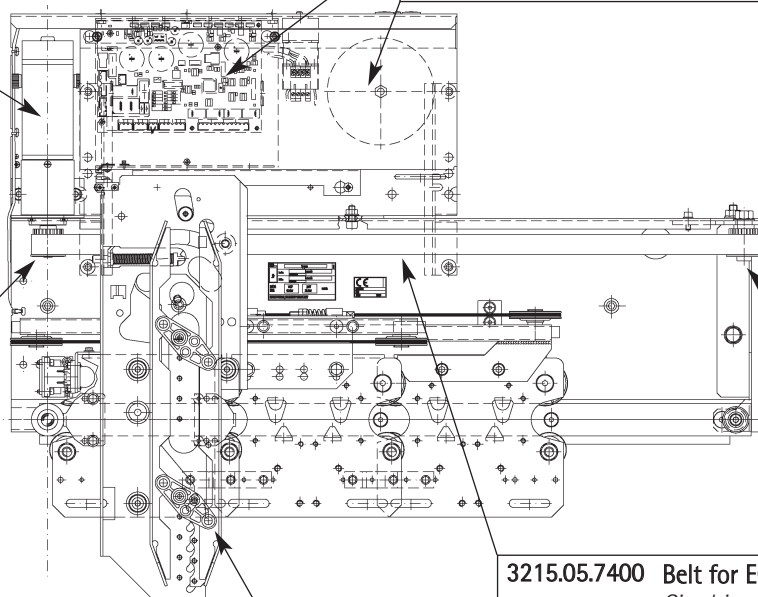

3215.05.0041 Motor pulley for ECO
Puleggia motore per ECO

3201.05.0096 Motor pulley for MIDI/SUPRA
Puleggia motore per MIDI/SUPRA

7024.00.010



See pg. 32-33
Vedere pag. 32-33

3215.05.7400 Belt for ECO door
Cinghia per porta ECO

3201.05.7315 Belt for MIDI/SUPRA door
Cinghia per porta MIDI/SUPRA

Specify door type and C.O.
Specificare il tipo porta e il P.L.

3215.04.0400 Idle pulley for ECO
Puleggia folle per ECO

3201.03.0266 Idle pulley for MIDI/SUPRA
Puleggia folle per MIDI/SUPRA



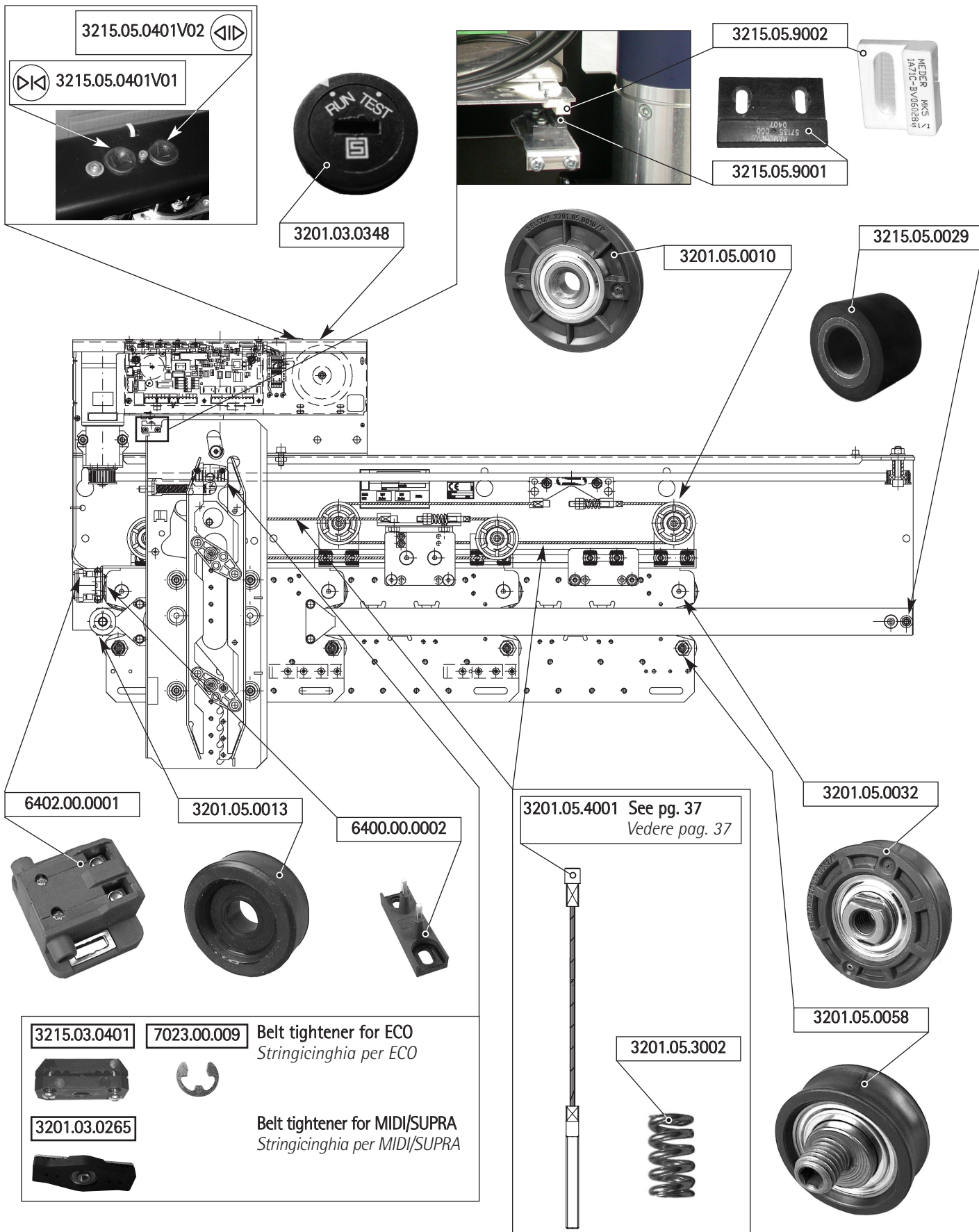



3215.03.0850 ECO Motor
Motore ECO

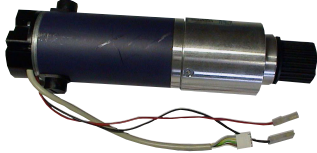

3201.04.0901V01 MIDI Motor
Motore MIDI



3201.04.0900V01 SUPRA Motor
Motore SUPRA

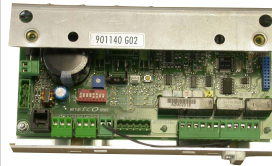

3215.15.7400 ECO board
Quadro ECO

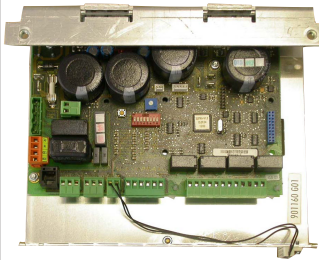

3201.03.0262 MIDI/SUPRA board
Quadro MIDI/SUPRA



3215.02.0852V02 ECO Transformer
Trasformatore ECO
(127÷230V)



3201.03.0263 MIDI/SUPRA Transformer
Trasformatore MIDI/SUPRA
(127÷230V)

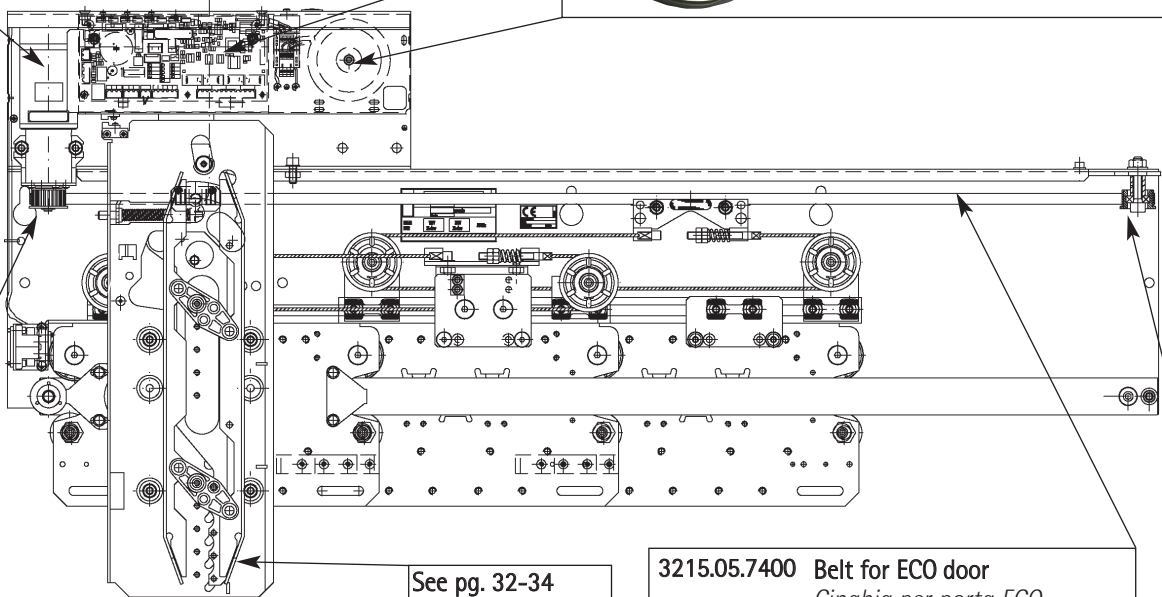

- 3215.05.0041 Motor pulley for ECO**
Puleggia motore per ECO
- 3201.05.0096 Motor pulley for MIDI/SUPRA**
Puleggia motore per MIDI/SUPRA

7024.00.010



See pg. 32-34
Vedere pag. 32-34

- 3215.05.7400 Belt for ECO door**
Cinghia per porta ECO
- 3201.05.7315 Belt for MIDI/SUPRA door**
Cinghia per porta MIDI/SUPRA

Specify door type and C.O.
Specificare il tipo porta e il P.L.

- 3215.04.0400 Idle pulley for ECO**
Puleggia folle per ECO

- 3201.03.0266 Idle pulley for MIDI/SUPRA**
Puleggia folle per MIDI/SUPRA



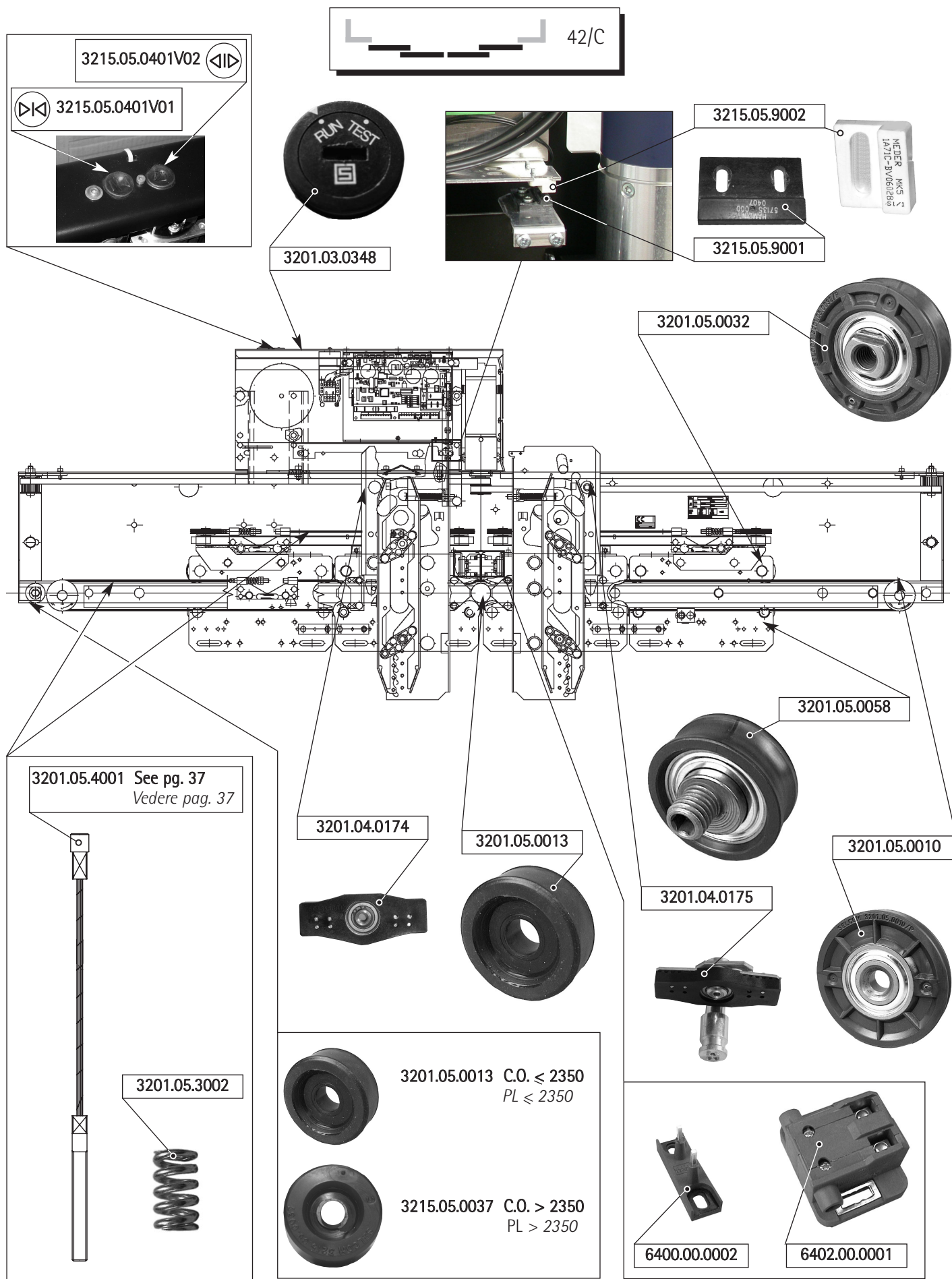

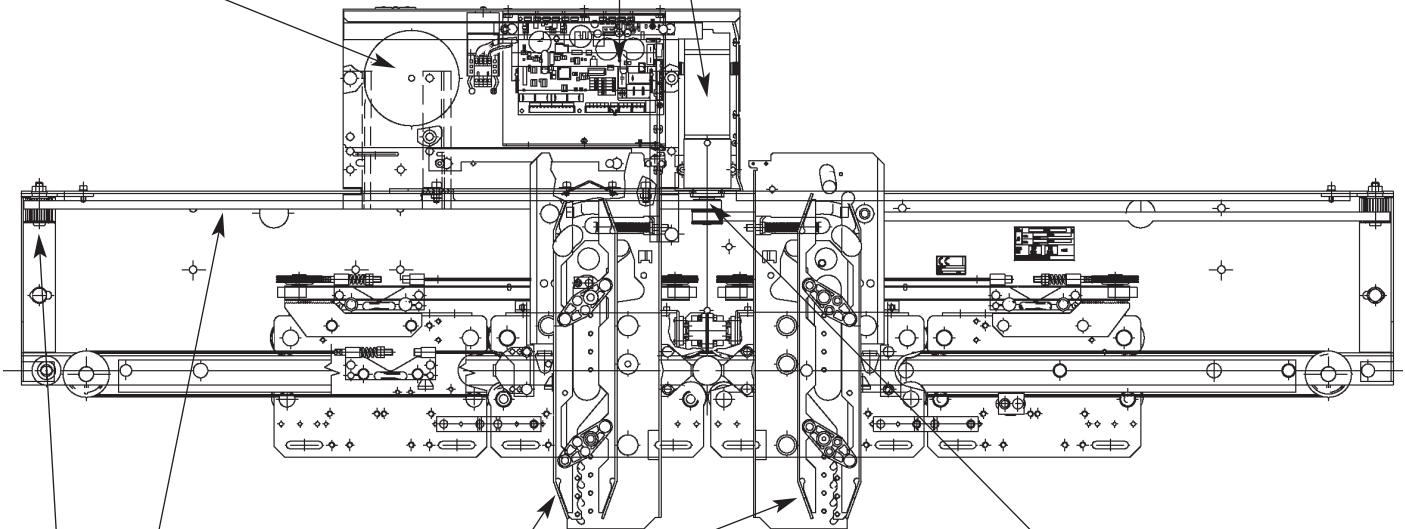
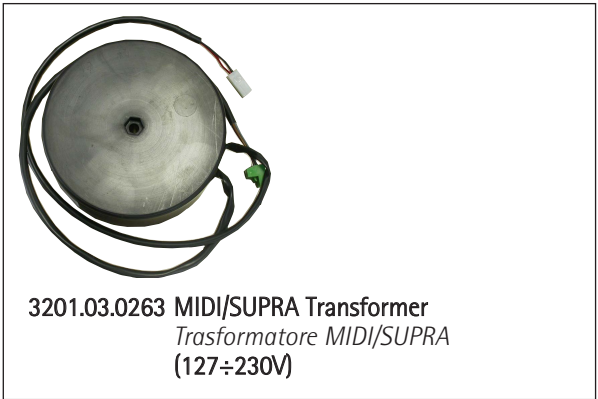
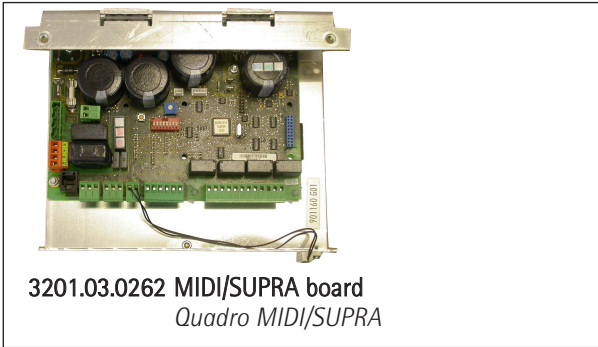

See pg. 26
Vedere pag. 26

3215.05.7400 Belt ECO
Cinghia ECO
Specify door type and C.O.
Specificare il tipo porta e il P.L.

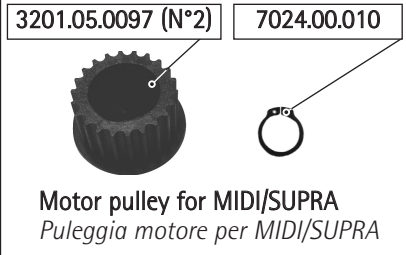

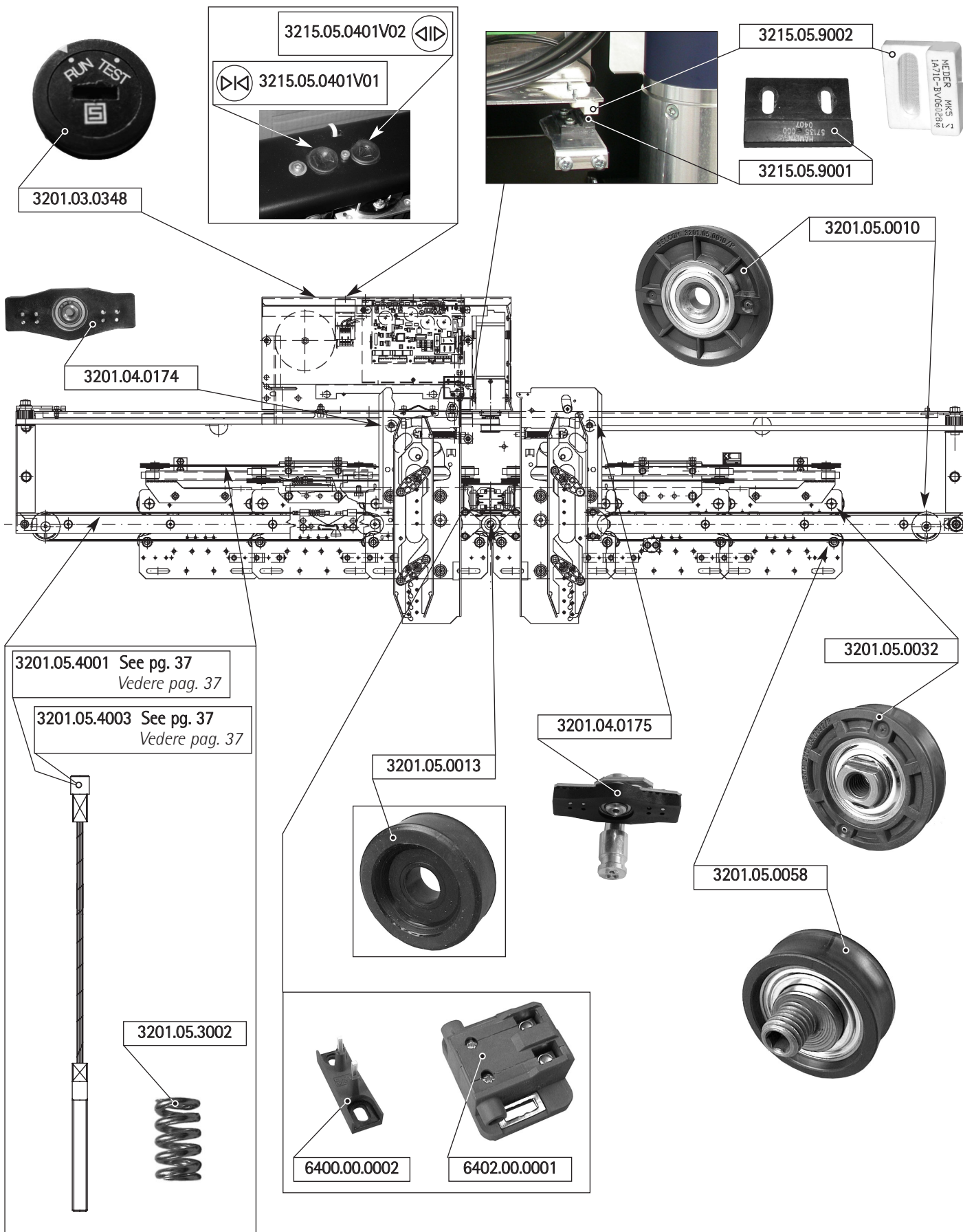

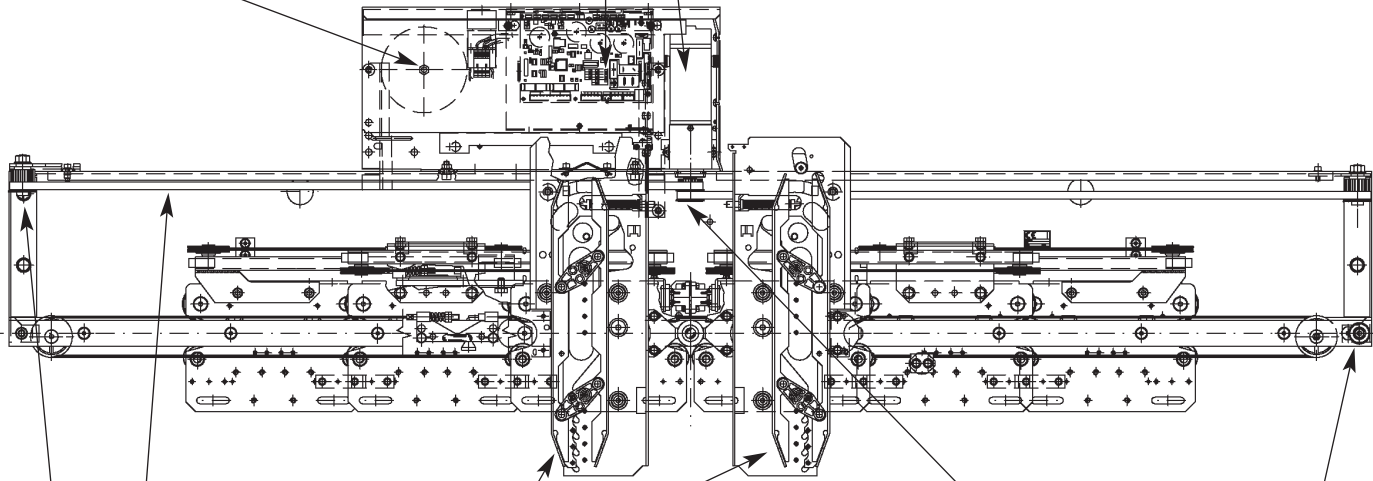
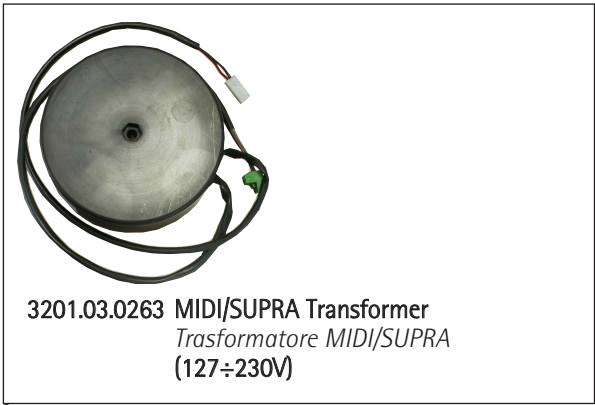
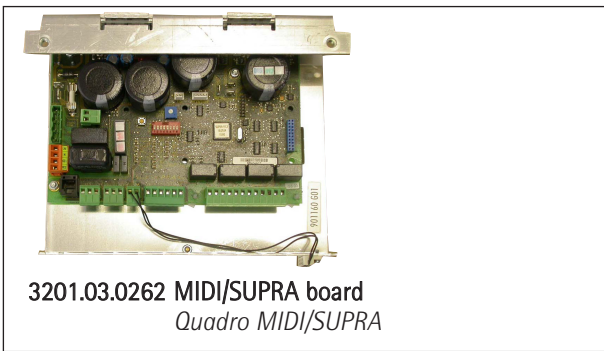

See pg. 26
Vedere pag. 26

3215.05.7400 Belt ECO
Cinghia ECO
Specify door type and C.O.
Specificare il tipo porta e il P.L.

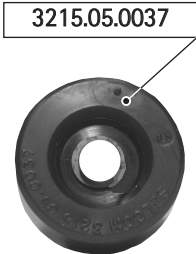
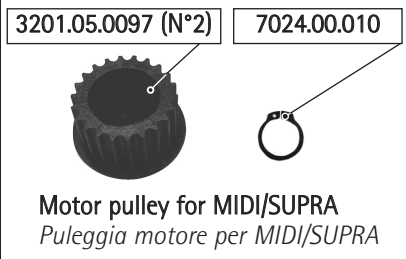



3215.05.0401V02



3215.05.0401V01

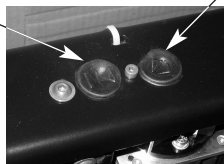

3201.03.0348

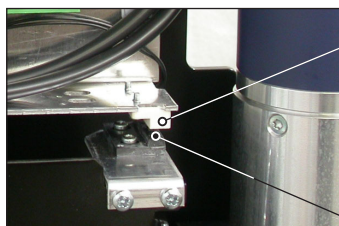

3215.05.9002



3215.05.9001



3201.05.0010



3201.05.5045

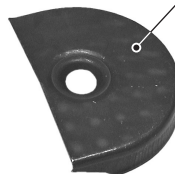

3215.05.0029



3201.05.4001 See pg. 37
Vedere pag. 37

3201.05.4003 See pg. 37
Vedere pag. 37



3201.05.3002



3212.04.0003



6400.00.0002



6402.00.0001



3201.05.0032



3201.05.0058



3215.03.0401

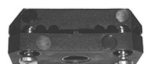

7023.00.009



Belt tightener for ECO
Stringinghia per ECO

3201.03.0265



Belt tightener for MIDI/SUPRA
Stringinghia per MIDI/SUPRA

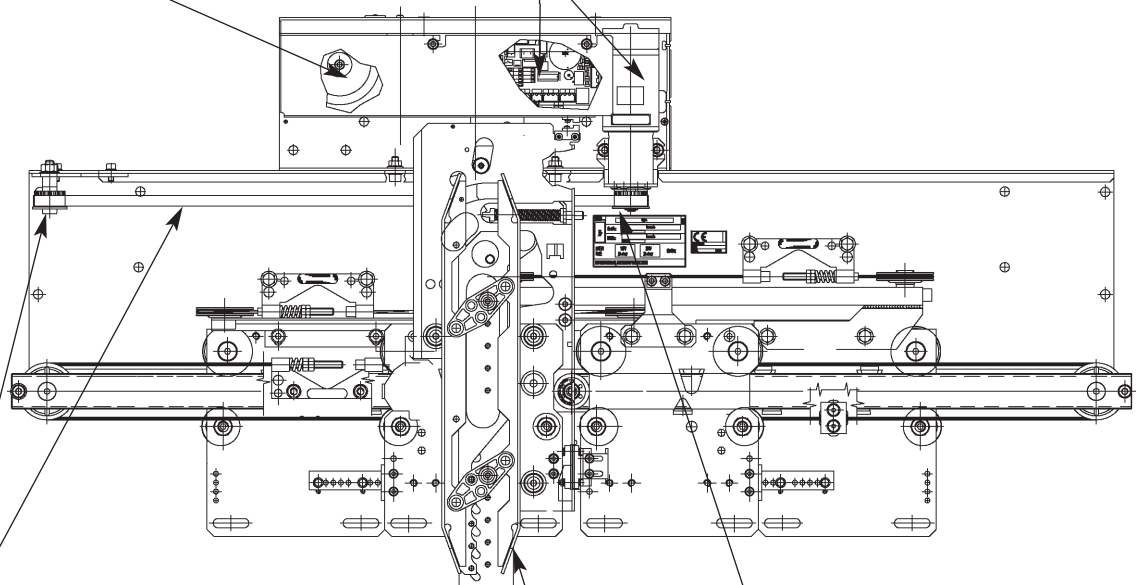
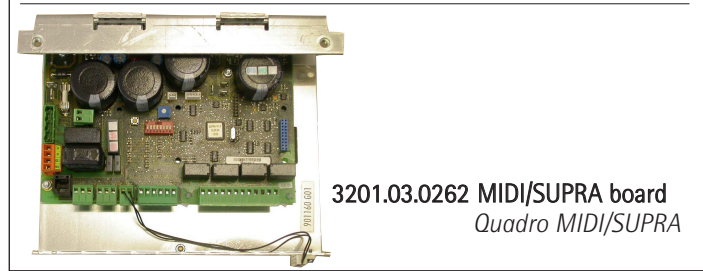
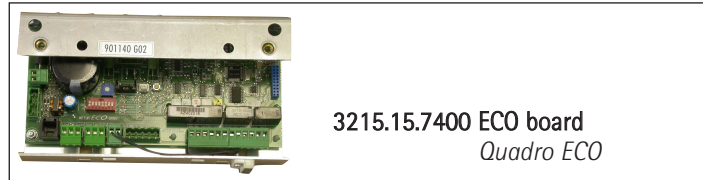

3215.05.7400 Belt for ECO door
Cinghia per porta ECO

3201.05.7315 Belt for MIDI door
Cinghia per porta MIDI

Specify door type and C.O.
Specificare il tipo porta e il P.L.

See pg. 24-25
Vedere pag. 24-25

3215.05.0041 Motor pulley for ECO
Puleggia motore per ECO

3201.05.0096 Motor pulley for MIDI
Puleggia motore per MIDI

7024.00.010

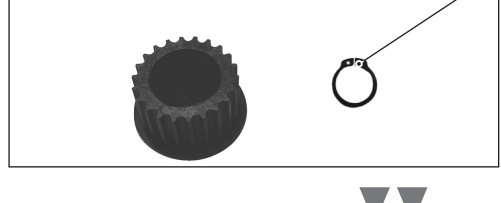
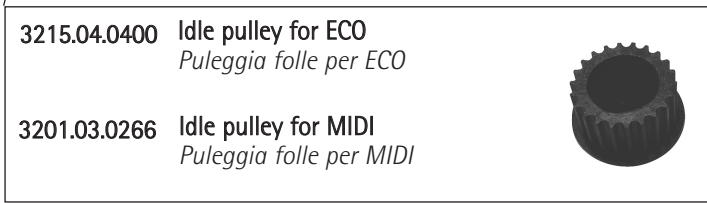

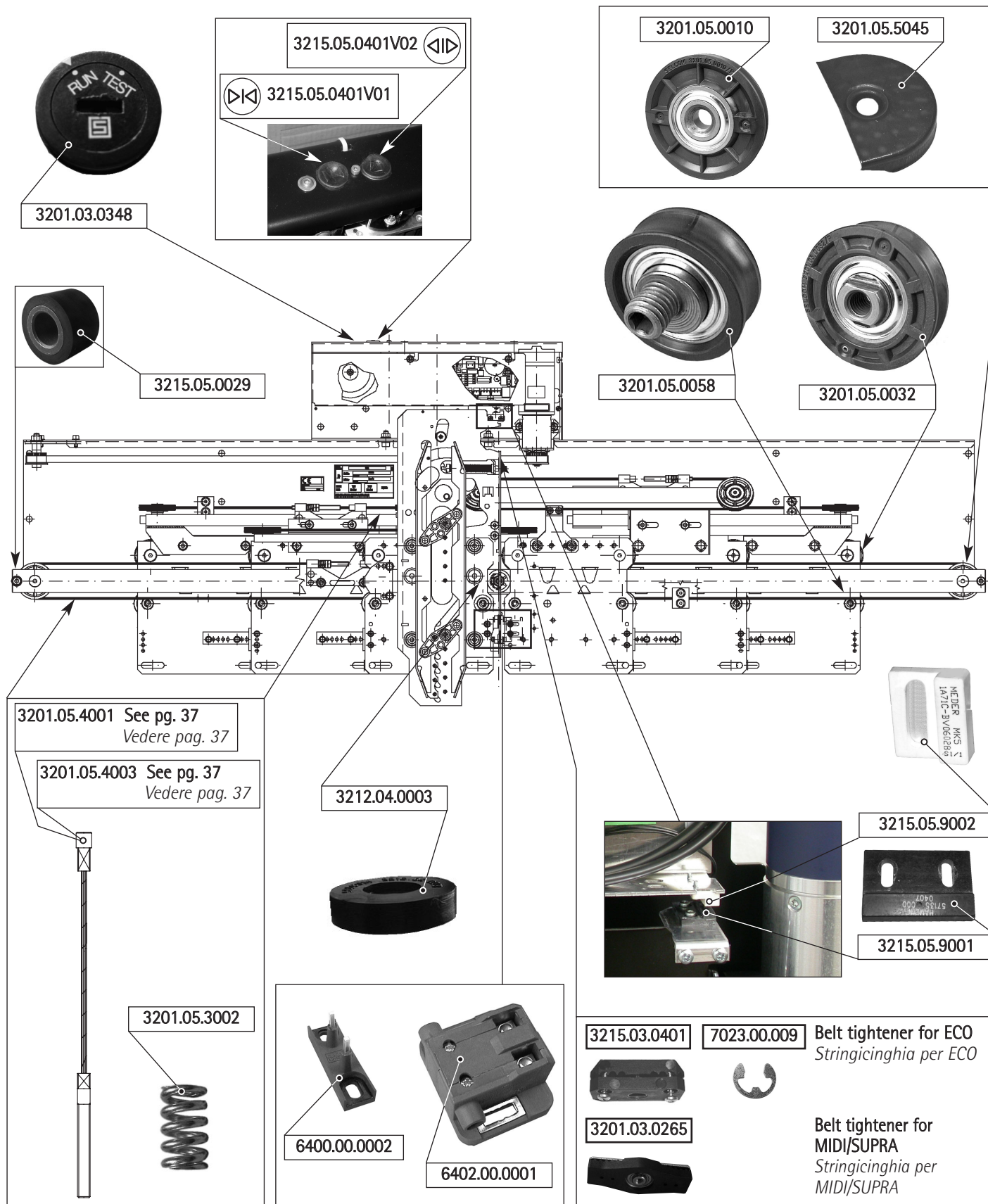

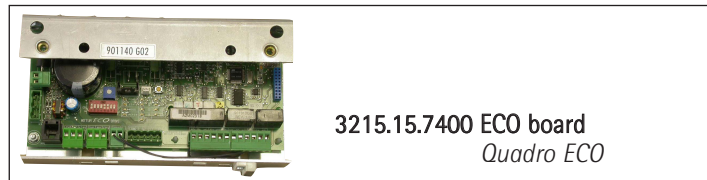

3215.15.7400 ECO board
Quadro ECO

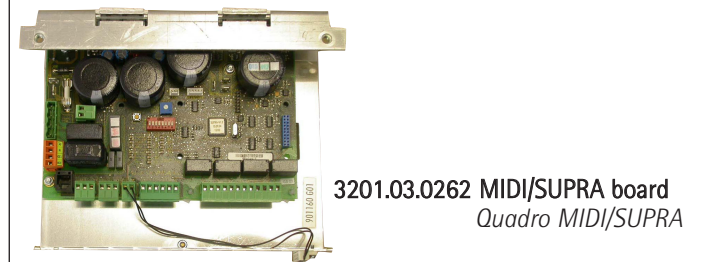

3201.03.0262 MIDI/SUPRA board
Quadro MIDI/SUPRA

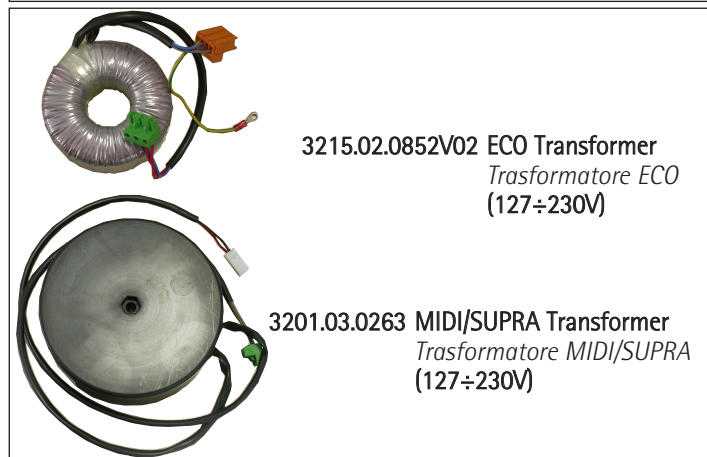

3215.02.0852V02 ECO Transformer
Trasformatore ECO
(127÷230V)

3201.03.0263 MIDI/SUPRA Transformer
Trasformatore MIDI/SUPRA
(127÷230V)



3215.03.0850 ECO Motor
Motore ECO



3201.04.0901V01 MIDI Motor
Motore MIDI



3201.04.0900V01 SUPRA Motor
Motore SUPRA

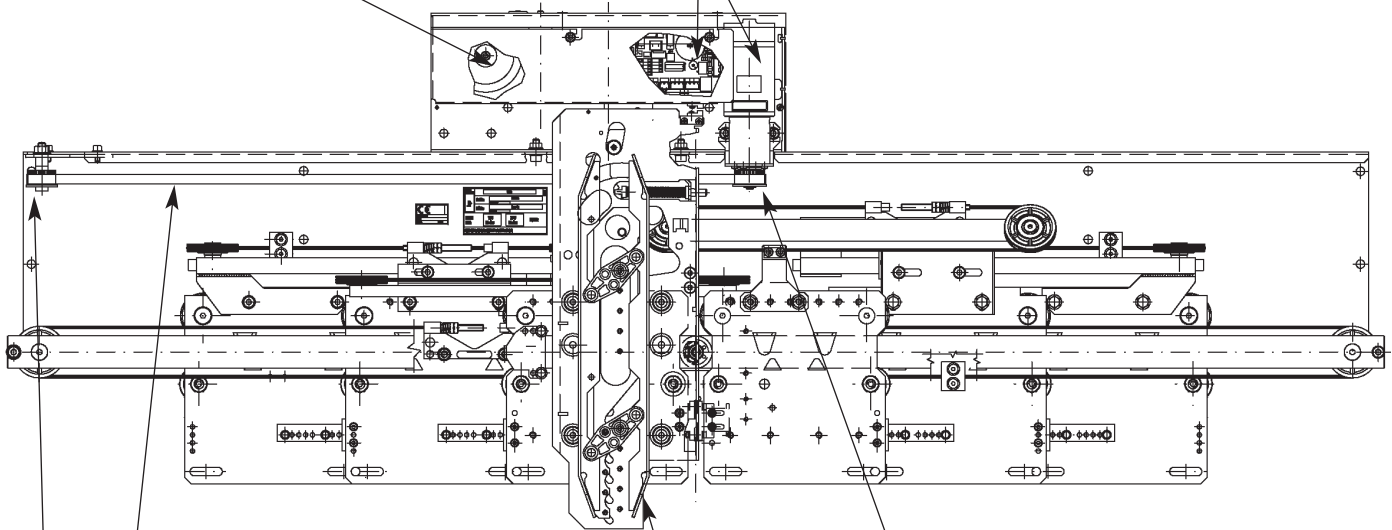

3215.05.7400 Belt for ECO door
Cinghia per porta ECO

3201.05.7315 Belt for MIDI door
Cinghia per porta MIDI

Specify door type and C.O.
Specificare il tipo porta e il P.L.

See pg. 24-25
Vedere pag. 24-25

3215.05.0041 Motor pulley for ECO
Puleggia motore per ECO

3201.05.0096 Motor pulley for MIDI
Puleggia motore per MIDI

7024.00.010

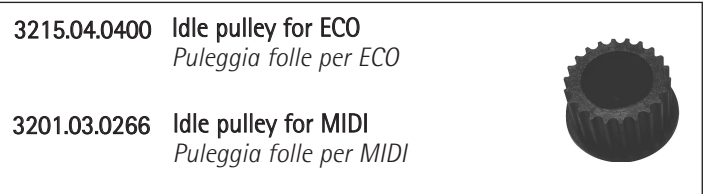

3215.04.0400 Idle pulley for ECO
Puleggia folle per ECO

3201.03.0266 Idle pulley for MIDI
Puleggia folle per MIDI

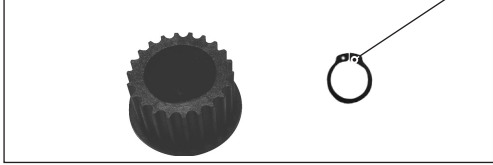

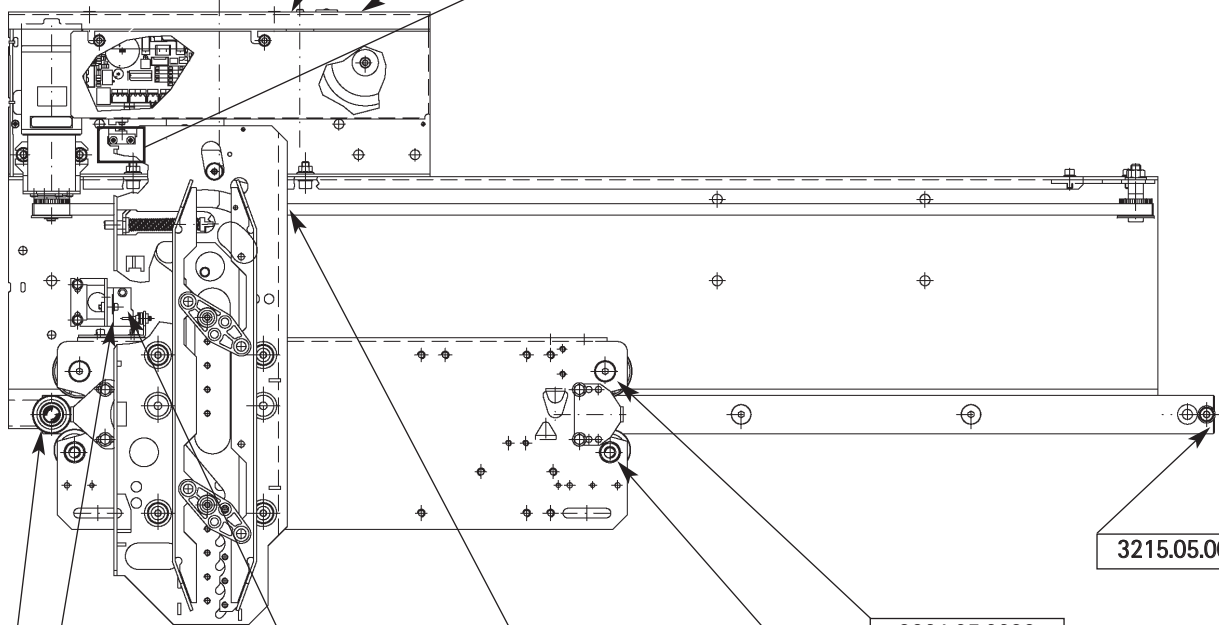
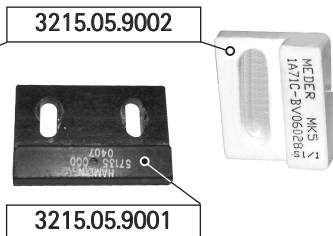
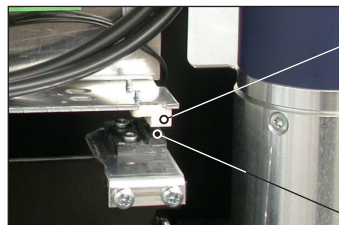
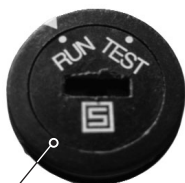
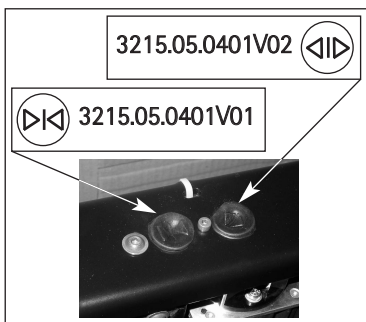

6402.00.0001

6400.00.0002



3201.05.0032

3201.05.0058

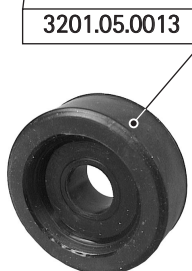
3215.05.0029

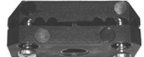

3201.05.0013

3215.03.0401	7023.00.009	Belt tightener for ECO <i>Stringicinghia per ECO</i>
		
3201.03.0265		Belt tightener for MIDI/SUPRA <i>Stringicinghia per MIDI/SUPRA</i>
		



3215.03.0850 ECO Motor
Motore ECO

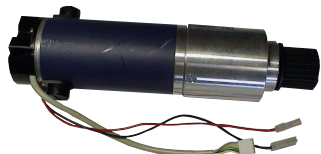

3201.04.0901V01 MIDI Motor
Motore MIDI



3201.04.0900V01 SUPRA Motor
Motore SUPRA

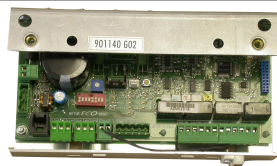

3215.15.7400 ECO board
Quadro ECO

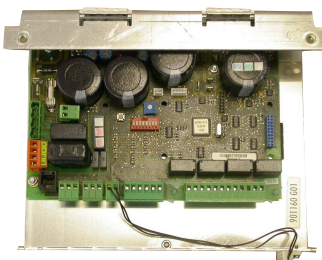

3201.03.0262 MIDI/SUPRA board
Quadro MIDI/SUPRA

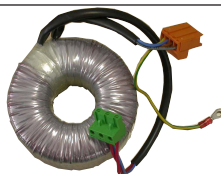

3215.02.0852V02 ECO Transformer
Trasformatore ECO
(127÷230V)



3201.03.0263 MIDI/SUPRA Transformer
Trasformatore MIDI/SUPRA
(127÷230V)

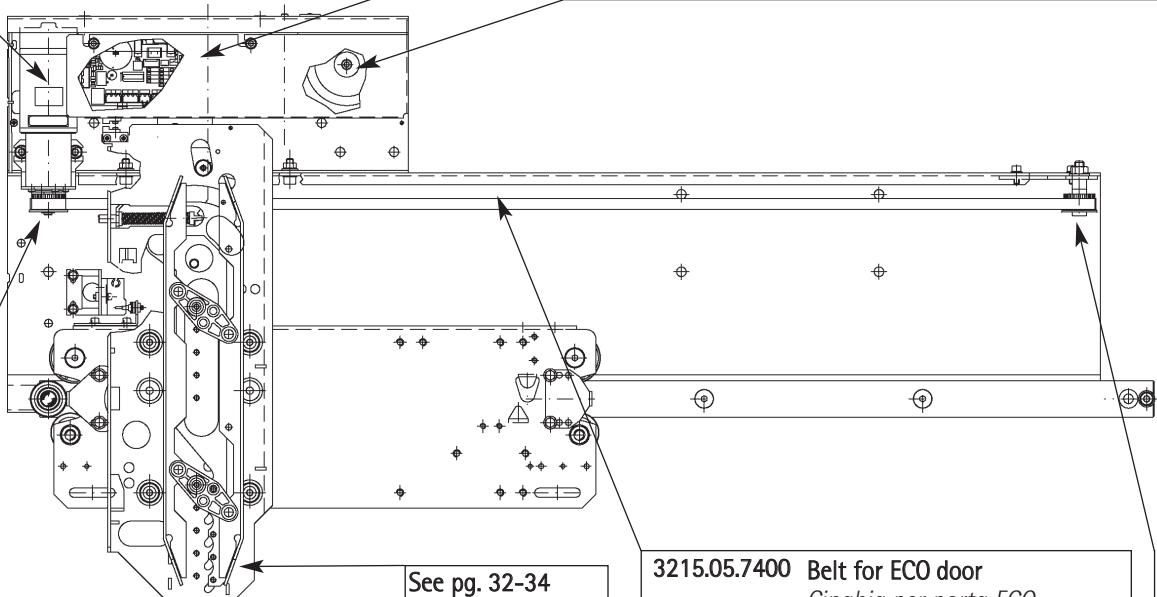

3215.05.0041 Motor pulley for ECO
Puleggia motore per ECO

3201.05.0096 Motor pulley for MIDI/SUPRA
Puleggia motore per MIDI/SUPRA

7024.00.010



See pg. 32-34
Vedere pag. 32-34

3215.05.7400 Belt for ECO door
Cinghia per porta ECO

3201.05.7315 Belt for MIDI/SUPRA door
Cinghia per porta MIDI/SUPRA

Specify door type and C.O.
Specificare il tipo porta e il P.L.

3215.04.0400 Idle pulley for ECO
Puleggia folle per ECO

3201.03.0266 Idle pulley for MIDI/SUPRA
Puleggia folle per MIDI/SUPRA



ECO HYDRA PLUS couplers

Abbinamenti ECO HYDRA PLUS



DOOR TYPE TIPO PORTA	CO / PL						NH	CAM OFFSET [mm] DISASSAMENTO [mm]	
	600	650	700	750	▶	1200			OVER OLTRE
	02/C	3201.12.0860V02						450	0-100
	02/C	3201.12.0860V04						300	
	02/C	3201.12.0860V06						450	125-250
	02/C	3201.12.0860V08						300	

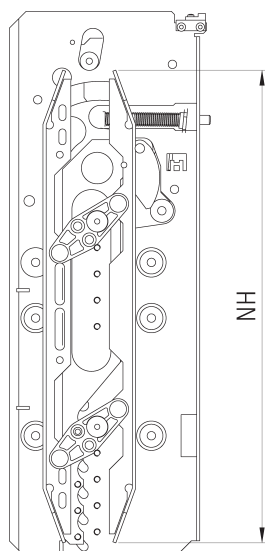

DOOR TYPE TIPO PORTA	CO / PL							NH	CAM OFFSET [mm] DISASSAMENTO [mm]	
	600	650	700	▶	850	900	▶			1200
	44/R	3201.12.0271V03				▶		3201.12.0271V04	450	0-100
	44/R	3201.12.0271V13				▶		3201.12.0271V14	300	
	44/R	3201.12.0271V08				▶		3201.12.0860V04	450	125-250
	44/R	3201.12.0271V18				▶		3201.12.0860V08	300	

DOOR TYPE TIPO PORTA	CO / PL							NH	CAM OFFSET [mm] DISASSAMENTO [mm]	
	600	650	700	▶	1150	1200	OVER OLTRE			
	66/C	3201.12.0271V03				▶		3201.12.0271V04	450	0-100
	66/C	3201.12.0271V13				▶		3201.12.0271V14	300	
	66/C	3201.12.0271V08				▶		3201.12.0860V04	450	125-250
	66/C	3201.12.0271V18				▶		3201.12.0860V08	300	

MIDI SUPRA couplers
Abbinamenti MIDI SUPRA

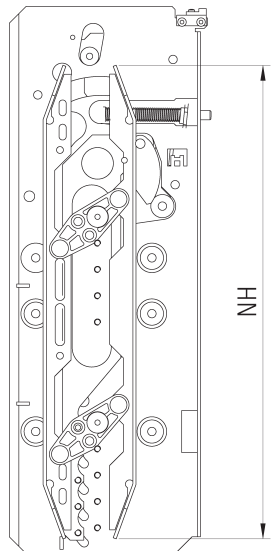

DOOR TYPE TIPO PORTA	CO / PL						NH	CAM OFFSET [mm] DISASSAMENTO [mm]
	600	650	700	750	1500	OVER OLTRE		
	02/C	3201.12.0266V06					300	0-100
	02/C	3201.12.0266V02					450	
	02/C	3201.12.0266V10					700	
	02/C	3201.12.0266V08					300	125-250
	02/C	3201.12.0266V04					450	
	02/C	3201.12.0266V12					700	

DOOR TYPE TIPO PORTA	CO / PL						NH	CAM OFFSET [mm] DISASSAMENTO [mm]
	600	650	700	850	900	1500		
	44/R	3201.12.0272V13			3201.12.0272V14		300	0-100
	44/R	3201.12.0272V03			3201.12.0272V04		450	
	44/R	3201.12.0272V23			3201.12.0272V24		700	
	44/R	3201.12.0272V18			3201.12.0272V19		300	125-250
	44/R	3201.12.0272V08			3201.12.0272V09		450	
	44/R	3201.12.0272V28			3201.12.0272V29		700	

DOOR TYPE TIPO PORTA	CO / PL						NH	CAM OFFSET [mm] DISASSAMENTO [mm]
	600	650	700	1150	1500	OVER OLTRE		
	66/C	3201.12.0272V13			3201.12.0272V14		300	0-100
	66/C	3201.12.0272V03			3201.12.0272V04		450	
	66/C	3201.12.0272V23			3201.12.0272V24		700	
	66/C	3201.12.0272V18			3201.12.0272V19		300	125-250
	66/C	3201.12.0272V08			3201.12.0272V09		450	
	66/C	3201.12.0272V28			3201.12.0272V29		700	

MIDI SUPRA 42 couplers

Abbinamenti MIDI SUPRA 42



42/C

DOOR TYPE TIPO PORTA	CO / PL				NH	CAM OFFSET [mm] DISASSAMENTO [mm]
	1200	1250	1300	1450 ▶ OVER OLTRE		
	42/SX	3201.12.0272V12			3201.12.0266V06	300
	42/DX	3201.12.0277V05			3201.12.0277V06	
	42/SX	3201.12.0272V02			3201.12.0266V02	450
	42/DX	3201.12.0277V01			3201.12.0277V02	
	42/SX	3201.12.0272V22			3201.12.0266V02	700
	42/DX	3201.12.0277V09			3201.12.0277V10	
	42/SX	3201.12.0272V17			3201.12.0266V08	300
	42/DX	3201.12.0277V07			3201.12.0277V08	
	42/SX	3201.12.0272V07			3201.12.0266V04	450
	42/DX	3201.12.0277V03			3201.12.0277V04	
	42/SX	3201.12.0272V27			3201.12.0266V12	700
	42/DX	3201.12.0277V11			3201.12.0277V12	

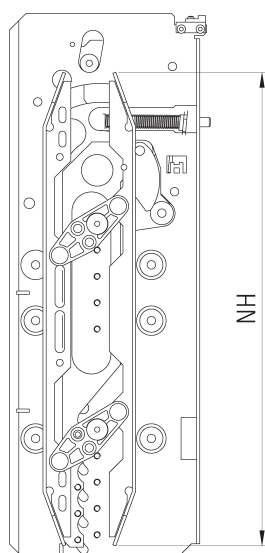

MIDI SUPRA 62 couplers

Abbinamenti MIDI SUPRA 62



62/C

DOOR TYPE TIPO PORTA	CO / PL				NH	CAM OFFSET [mm] DISASSAMENTO [mm]
	1500	1550	1600	2250 ▶ OVER OLTRE		
	62/SX	3201.12.0272V12			3201.12.0266V06	300
	62/DX	3201.12.0277V05			3201.12.0277V06	
	62/SX	3201.12.0272V02			3201.12.0266V02	450
	62/DX	3201.12.0277V01			3201.12.0277V02	
	62/SX	3201.12.0272V22			3201.12.0266V02	700
	62/DX	3201.12.0277V09			3201.12.0277V10	
	62/SX	3201.12.0272V17			3201.12.0266V08	300
	62/DX	3201.12.0277V07			3201.12.0277V08	
	62/SX	3201.12.0272V07			3201.12.0266V04	450
	62/DX	3201.12.0277V03			3201.12.0277V04	
	62/SX	3201.12.0272V27			3201.12.0266V12	700
	62/DX	3201.12.0277V11			3201.12.0277V12	

ECO HYDRA PLUS couplers
Abbinamenti ECO HYDRA PLUS



DOOR TYPE TIPO PORTA	CO / PL						NH	CAM OFFSET [mm] DISASSAMENTO [mm]
	600	650	700	750	▶ 1200	OVER OLTRE		
	12/R	3201.12.0271V01			3201.12.0860V01		450	0-100
	12/R	3201.12.0271V11			3201.12.0860V05		300	
	12/R	3201.12.0271V05			3201.12.0860V03		450	125-250
	12/R	3201.12.0271V15			3201.12.0860V07		300	
	12/L	3201.12.0271V02			3201.12.0860V02		450	0-100
	12/L	3201.12.0271V12			3201.12.0860V06		300	
	12/L	3201.12.0271V07			3201.12.0860V04		450	125-250
	12/L	3201.12.0271V17			3201.12.0860V08		300	

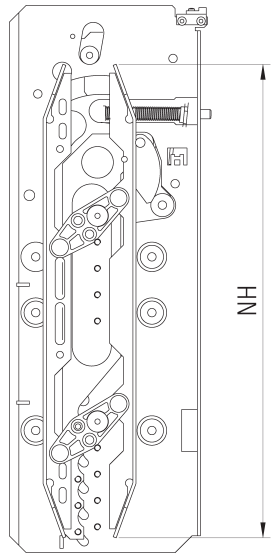

DOOR TYPE TIPO PORTA	CO / PL						NH	CAM OFFSET [mm] DISASSAMENTO [mm]
	600	▶ 1100	1150	1200	OVER OLTRE			
	32/R	3201.12.0271V01			3201.12.0860V01		450	0-100
	32/R	3201.12.0271V11			3201.12.0860V05		300	
	32/R	3201.12.0271V05			3201.12.0860V03		450	125-250
	32/R	3201.12.0271V15			3201.12.0860V07		300	
	32/L	3201.12.0271V02			3201.12.0860V02		450	0-100
	32/L	3201.12.0271V12			3201.12.0860V06		300	
	32/L	3201.12.0271V07			3201.12.0860V04		450	125-250
	32/L	3201.12.0271V17			3201.12.0860V08		300	

DOOR TYPE TIPO PORTA	CO / PL						NH	CAM OFFSET [mm] DISASSAMENTO [mm]
	600	▶ 1100	1150	1200	OVER OLTRE			
	35/R	3201.12.0271V01			3201.12.0860V01		450	0-100
	35/R	3201.12.0271V11			3201.12.0860V05		300	
	35/R	3201.12.0271V05			3201.12.0860V03		450	125-250
	35/R	3201.12.0271V15			3201.12.0860V07		300	
	35/L	3201.12.0271V02			3201.12.0860V02		450	0-100
	35/L	3201.12.0271V12			3201.12.0860V06		300	
	35/L	3201.12.0271V07			3201.12.0860V04		450	125-250
	35/L	3201.12.0271V17			3201.12.0860V08		300	



DOOR TYPE TIPO PORTA	CO / PL						NH	CAM OFFSET [mm] DISASSAMENTO [mm]
	600	650	700	750	▶ 1200	OVER OLTRE		
	72/R	3201.12.0860V01					450	0-100
	72/R	3201.12.0860V05					300	
	72/R	3201.12.0860V03					450	125-250
	72/R	3201.12.0860V07					300	
	72/L	3201.12.0860V02					450	0-100
	72/L	3201.12.0860V06					300	
	72/L	3201.12.0860V04					450	125-250
	72/L	3201.12.0860V08					300	

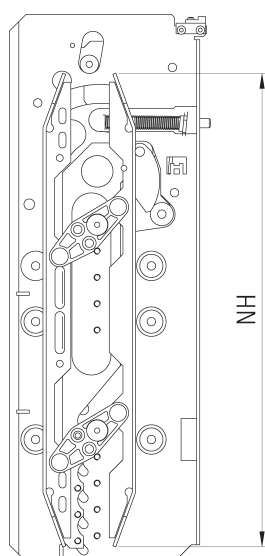

MIDI SUPRA couplers

Abbinamenti MIDI SUPRA



 12/R-L

 32/R-L

DOOR TYPE TIPO PORTA	CO / PL						NH	CAM OFFSET [mm] DISASSAMENTO [mm]
	600	650	700	750	▶ 1500	OVER OLTRE		
	12/R	3201.12.0272V11			3201.12.0266V05		300	0-100
	12/R	3201.12.0272V01			3201.12.0266V01		450	
	12/R	3201.12.0272V21			3201.12.0266V09		700	
	12/R	3201.12.0272V16			3201.12.0266V07		300	125-250
	12/R	3201.12.0272V06			3201.12.0266V03		450	
	12/R	3201.12.0272V26			3201.12.0266V11		700	
	12/L	3201.12.0272V12			3201.12.0266V06		300	0-100
	12/L	3201.12.0272V02			3201.12.0266V02		450	
	12/L	3201.12.0272V22			3201.12.0266V10		700	
	12/L	3201.12.0272V17			3201.12.0266V08		300	125-250
	12/L	3201.12.0272V07			3201.12.0266V04		450	
	12/L	3201.12.0272V27			3201.12.0266V12		700	

DOOR TYPE TIPO PORTA	CO / PL					NH	CAM OFFSET [mm] DISASSAMENTO [mm]
	600	▶ 1100	1150	▶ 1500	OVER OLTRE		
	32/R	3201.12.0272V11		3201.12.0266V05		300	0-100
	32/R	3201.12.0272V01		3201.12.0266V01		450	
	32/R	3201.12.0272V21		3201.12.0266V09		700	
	32/R	3201.12.0272V16		3201.12.0266V07		300	125-250
	32/R	3201.12.0272V06		3201.12.0266V03		450	
	32/R	3201.12.0272V26		3201.12.0266V11		700	
	32/L	3201.12.0272V12		3201.12.0266V06		300	0-100
	32/L	3201.12.0272V02		3201.12.0266V02		450	
	32/L	3201.12.0272V22		3201.12.0266V10		700	
	32/L	3201.12.0272V17		3201.12.0266V08		300	125-250
	32/L	3201.12.0272V07		3201.12.0266V04		450	
	32/L	3201.12.0272V27		3201.12.0266V12		700	

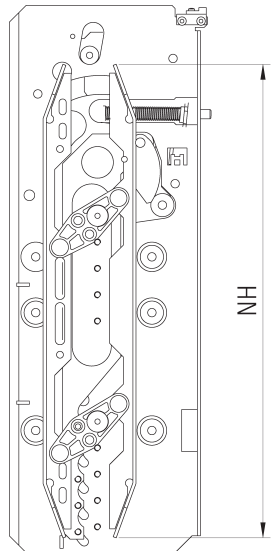
MIDI SUPRA couplers
Abbinamenti MIDI SUPRA



DOOR TYPE <i>TIPO PORTA</i>	CO / PL				NH	CAM OFFSET [mm] <i>DISASSAMENTO [mm]</i>
	600	1100	1150	1500		
	35/R	3201.12.0272V11		3201.12.0266V05	300	0-100
	35/R	3201.12.0272V01		3201.12.0266V01	450	
	35/R	3201.12.0272V21		3201.12.0266V09	700	
	35/R	3201.12.0272V16		3201.12.0266V07	300	125-250
	35/R	3201.12.0272V06		3201.12.0266V03	450	
	35/R	3201.12.0272V26		3201.12.0266V11	700	
	35/L	3201.12.0272V12		3201.12.0266V06	300	0-100
	35/L	3201.12.0272V02		3201.12.0266V02	450	
	35/L	3201.12.0272V22		3201.12.0266V10	700	
	35/L	3201.12.0272V17		3201.12.0266V08	300	125-250
	35/L	3201.12.0272V07		3201.12.0266V04	450	
	35/L	3201.12.0272V27		3201.12.0266V12	700	

DOOR TYPE <i>TIPO PORTA</i>	CO / PL						NH	CAM OFFSET [mm] <i>DISASSAMENTO [mm]</i>
	600	650	700	750	1500	OVER <i>OLTRE</i>		
	72/R				3201.12.0266V05		300	0-100
	72/R				3201.12.0266V01		450	
	72/R				3201.12.0266V09		700	
	72/R				3201.12.0266V07		300	125-250
	72/R				3201.12.0266V03		450	
	72/R				3201.12.0266V11		700	
	72/L				3201.12.0266V06		300	0-100
	72/L				3201.12.0266V02		450	
	72/L				3201.12.0266V10		700	
	72/L				3201.12.0266V08		300	125-250
	72/L				3201.12.0266V04		450	
	72/L				3201.12.0266V12		700	

ECO HYDRA PLUS couplers with car door lock
Abbinamenti con bloccaggio fuori piano ECO HYDRA PLUS

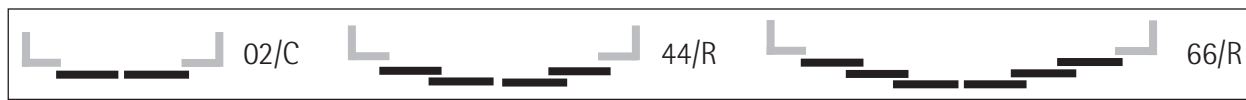

DOOR TYPE TIPO PORTA	CO / PL						NH	CAM OFFSET [mm] DISASSAMENTO [mm]	
	600	650	700	750	▶	1200			OVER OLTRE
	02/C	3201.12.0273V02						450	0-100
	02/C	3201.12.0273V04						300	
	02/C	3201.12.0273V06						450	125-250
	02/C	3201.12.0273V08						300	

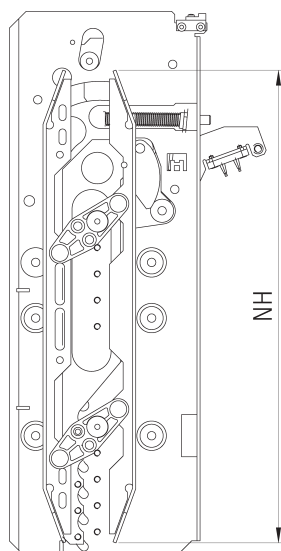

DOOR TYPE TIPO PORTA	CO / PL						NH	CAM OFFSET [mm] DISASSAMENTO [mm]	
	600	650	700	▶	850	900			▶
	44/R	3201.12.0275V03			3201.12.0275V04			450	0-100
	44/R	3201.12.0275V13			3201.12.0275V14			300	
	44/R	3201.12.0275V08			3201.12.0273V04			450	125-250
	44/R	3201.12.0275V18			3201.12.0273V08			300	

DOOR TYPE TIPO PORTA	CO / PL						NH	CAM OFFSET [mm] DISASSAMENTO [mm]	
	600	650	700	▶	1150	1200			OVER OLTRE
	66/C	3201.12.0275V03			3201.12.0275V04			450	0-100
	66/C	3201.12.0275V13			3201.12.0275V14			300	
	66/C	3201.12.0275V08			3201.12.0273V04			450	125-250
	66/C	3201.12.0275V18			3201.12.0273V08			300	

MIDI SUPRA couplers with car door lock
Abbinamenti con bloccaggio fuori piano MIDI SUPRA



DOOR TYPE TIPO PORTA	CO / PL						NH	CAM OFFSET [mm] DISASSAMENTO [mm]
	600	650	700	750	▶ 1500	OVER OLTRE		
	02/C	3201.12.0274V06					300	0-100
	02/C	3201.12.0274V02					450	
	02/C	3201.12.0274V10					700	
	02/C	3201.12.0274V08					300	125-250
	02/C	3201.12.0274V04					450	
	02/C	3201.12.0274V12					700	

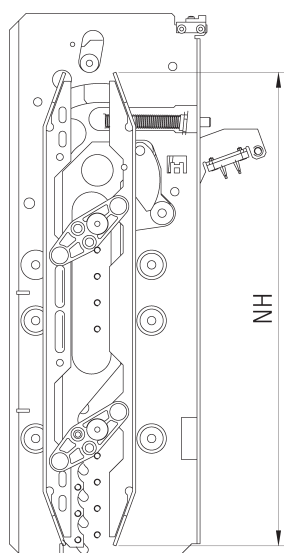

DOOR TYPE TIPO PORTA	CO / PL						NH	CAM OFFSET [mm] DISASSAMENTO [mm]
	600	650	700	▶ 850	▶ 900	▶ 1500		
	44/R	3201.12.0276V13			3201.12.0276V14		300	0-100
	44/R	3201.12.0276V03			3201.12.0276V04		450	
	44/R	3201.12.0276V23			3201.12.0276V24		700	
	44/R	3201.12.0276V18			3201.12.0276V19		300	125-250
	44/R	3201.12.0276V08			3201.12.0276V09		450	
	44/R	3201.12.0276V28			3201.12.0276V29		700	

DOOR TYPE TIPO PORTA	CO / PL						NH	CAM OFFSET [mm] DISASSAMENTO [mm]
	600	650	700	▶ 1150	1500	OVER OLTRE		
	66/C	3201.12.0276V13			3201.12.0276V14		300	0-100
	66/C	3201.12.0276V03			3201.12.0276V04		450	
	66/C	3201.12.0276V23			3201.12.0276V24		700	
	66/C	3201.12.0276V18			3201.12.0276V19		300	125-250
	66/C	3201.12.0276V08			3201.12.0276V09		450	
	66/C	3201.12.0276V28			3201.12.0276V29		700	

MIDI SUPRA 42 couplers with car door lock

Abbinamenti con bloccaggio fuori piano MIDI SUPRA 42



DOOR TYPE TIPO PORTA	CO / PL				NH	CAM OFFSET [mm] DISASSAMENTO [mm]
	1200	1250	1300	1450 ▶ OVER OLTRE		
	42/SX	3201.12.0276V12		3201.12.0274V06	300	0-100
	42/DX	3201.12.0277V05		3201.12.0277V06		
	42/SX	3201.12.0276V02		3201.12.0274V02	450	
	42/DX	3201.12.0277V01		3201.12.0277V02		
	42/SX	3201.12.0276V22		3201.12.0274V02	700	
	42/DX	3201.12.0277V09		3201.12.0277V10		
	42/SX	3201.12.0276V17		3201.12.0274V08	300	125-250
	42/DX	3201.12.0277V07		3201.12.0277V08		
	42/SX	3201.12.0276V07		3201.12.0274V04	450	
	42/DX	3201.12.0277V03		3201.12.0277V04		
	42/SX	3201.12.0276V27		3201.12.0274V12	700	
	42/DX	3201.12.0277V11		3201.12.0277V12		

MIDI SUPRA 62 couplers with car door lock

Abbinamenti con bloccaggio fuori piano MIDI SUPRA 62



DOOR TYPE TIPO PORTA	CO / PL				NH	CAM OFFSET [mm] DISASSAMENTO [mm]
	1500	1550	1600	2250 ▶ OVER OLTRE		
	62/SX	3201.12.0276V12		3201.12.0274V06	300	0-100
	62/DX	3201.12.0277V05		3201.12.0277V06		
	62/SX	3201.12.0276V02		3201.12.0274V02	450	
	62/DX	3201.12.0277V01		3201.12.0277V02		
	62/SX	3201.12.0276V22		3201.12.0274V02	700	
	62/DX	3201.12.0277V09		3201.12.0277V10		
	62/SX	3201.12.0276V17		3201.12.0274V08	300	125-250
	62/DX	3201.12.0277V07		3201.12.0277V08		
	62/SX	3201.12.0276V07		3201.12.0274V04	450	
	62/DX	3201.12.0277V03		3201.12.0277V04		
	62/SX	3201.12.0276V27		3201.12.0274V12	700	
	62/DX	3201.12.0277V11		3201.12.0277V12		

ECO HYDRA PLUS couplers with car door lock
Abbinamenti con bloccaggio fuori piano ECO HYDRA PLUS



DOOR TYPE TIPO PORTA	CO / PL						NH	CAM OFFSET [mm] DISASSAMENTO [mm]
	600	650	700	750	▶ 1200	OVER OLTRE		
	12/R	3201.12.0275V01			3201.12.0273V01		450	0-100
	12/R	3201.12.0275V11			3201.12.0273V05		300	
	12/R	3201.12.0275V05			3201.12.0273V03		450	125-250
	12/R	3201.12.0275V15			3201.12.0273V07		300	
	12/L	3201.12.0275V02			3201.12.0273V02		450	0-100
	12/L	3201.12.0275V12			3201.12.0273V06		300	
	12/L	3201.12.0275V07			3201.12.0273V04		450	125-250
	12/L	3201.12.0275V17			3201.12.0273V08		300	

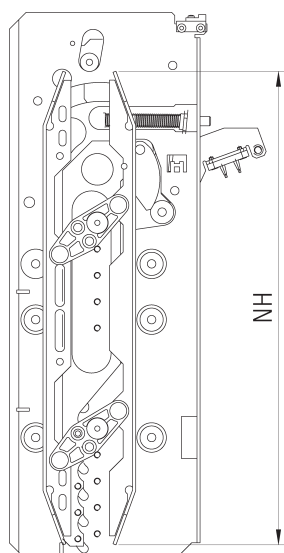

DOOR TYPE TIPO PORTA	CO / PL						NH	CAM OFFSET [mm] DISASSAMENTO [mm]
	600	▶ 1100	1150	1200	OVER OLTRE			
	32/R	3201.12.0275V01			3201.12.0273V01		450	0-100
	32/R	3201.12.0275V11			3201.12.0273V05		300	
	32/R	3201.12.0275V05			3201.12.0273V03		450	125-250
	32/R	3201.12.0275V15			3201.12.0273V07		300	
	32/L	3201.12.0275V02			3201.12.0273V02		450	0-100
	32/L	3201.12.0275V12			3201.12.0273V06		300	
	32/L	3201.12.0275V07			3201.12.0273V04		450	125-250
	32/L	3201.12.0275V17			3201.12.0273V08		300	

DOOR TYPE TIPO PORTA	CO / PL						NH	CAM OFFSET [mm] DISASSAMENTO [mm]
	600	▶ 1100	1150	1200	OVER OLTRE			
	35/R	3201.12.0275V01			3201.12.0273V01		450	0-100
	35/R	3201.12.0275V11			3201.12.0273V05		300	
	35/R	3201.12.0275V05			3201.12.0273V03		450	125-250
	35/R	3201.12.0275V15			3201.12.0273V07		300	
	35/L	3201.12.0275V02			3201.12.0273V02		450	0-100
	35/L	3201.12.0275V12			3201.12.0273V06		300	
	35/L	3201.12.0275V07			3201.12.0273V04		450	125-250
	35/L	3201.12.0275V17			3201.12.0273V08		300	

DOOR TYPE TIPO PORTA	CO / PL						NH	CAM OFFSET [mm] DISASSAMENTO [mm]
	600	650	700	750	▶ 1200	OVER OLTRE		
	72/R	3201.12.0275V01			3201.12.0273V01		450	0-100
	72/R	3201.12.0275V11			3201.12.0273V05		300	
	72/R	3201.12.0275V05			3201.12.0273V03		450	125-250
	72/R	3201.12.0275V15			3201.12.0273V07		300	
	72/L	3201.12.0275V02			3201.12.0273V02		450	0-100
	72/L	3201.12.0275V12			3201.12.0273V06		300	
	72/L	3201.12.0275V07			3201.12.0273V04		450	125-250
	72/L	3201.12.0275V17			3201.12.0273V08		300	

MIDI SUPRA couplers with car door lock
Abbinamenti con bloccaggio fuori piano MIDI SUPRA





12/R-L

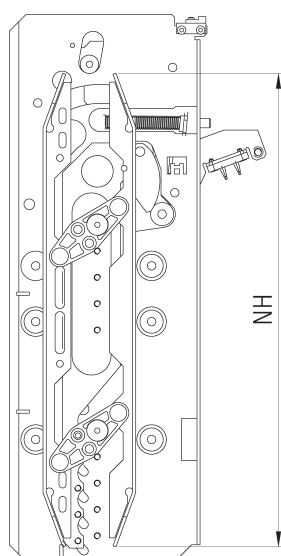

32/R-L

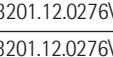
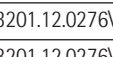

DOOR TYPE TIPO PORTA	CO / PL						NH	CAM OFFSET [mm] DISASSAMENTO [mm]
	600	650	700	750	▶ 1500	OVER OLTRE		
	12/R	3201.12.0276V11				3201.12.0274V05	300	0-100
	12/R	3201.12.0276V01				3201.12.0274V01	450	
	12/R	3201.12.0276V21				3201.12.0274V09	700	
	125-250	12/R	3201.12.0276V16				3201.12.0274V07	300
		12/R	3201.12.0276V06				3201.12.0274V03	450
		12/R	3201.12.0276V26				3201.12.0274V11	700
	12/L	3201.12.0276V12				3201.12.0274V06	300	0-100
	12/L	3201.12.0276V02				3201.12.0274V02	450	
	12/L	3201.12.0276V22				3201.12.0274V10	700	
	125-250	12/L	3201.12.0276V17				3201.12.0274V08	300
		12/L	3201.12.0276V07				3201.12.0274V04	450
		12/L	3201.12.0276V27				3201.12.0274V12	700

DOOR TYPE TIPO PORTA	CO / PL					NH	CAM OFFSET [mm] DISASSAMENTO [mm]	
	600	▶ 1100	1150	▶ 1500	OVER OLTRE			
	32/R	3201.12.0276V11				3201.12.0274V05	300	0-100
	32/R	3201.12.0276V01				3201.12.0274V01	450	
	32/R	3201.12.0276V21				3201.12.0274V09	700	
	125-250	32/R	3201.12.0276V16				3201.12.0274V07	300
		32/R	3201.12.0276V06				3201.12.0274V03	450
		32/R	3201.12.0276V26				3201.12.0274V11	700
	32/L	3201.12.0276V12				3201.12.0274V06	300	0-100
	32/L	3201.12.0276V02				3201.12.0274V02	450	
	32/L	3201.12.0276V22				3201.12.0274V10	700	
	125-250	32/L	3201.12.0276V17				3201.12.0274V08	300
		32/L	3201.12.0276V07				3201.12.0274V04	450
		32/L	3201.12.0276V27				3201.12.0274V12	700

MIDI SUPRA couplers with car door lock
Abbinamenti con bloccaggio fuori piano MIDI SUPRA

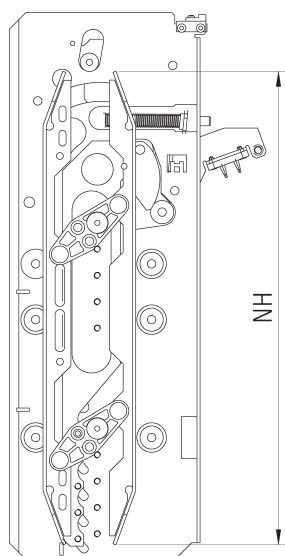
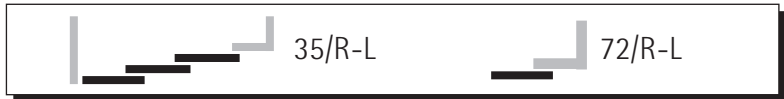

DOOR TYPE TIPO PORTA	CO / PL				NH	CAM OFFSET [mm] DISASSAMENTO [mm]
	600	1100	1150	1500		
	35/R	3201.12.0276V11		3201.12.0274V05	300	0-100
	35/R	3201.12.0276V01		3201.12.0274V01	450	
	35/R	3201.12.0276V21		3201.12.0274V09	700	
	35/R	3201.12.0276V16		3201.12.0274V07	300	125-250
	35/R	3201.12.0276V06		3201.12.0274V03	450	
	35/R	3201.12.0276V26		3201.12.0274V11	700	
	35/L	3201.12.0276V12		3201.12.0274V06	300	0-100
	35/L	3201.12.0276V02		3201.12.0274V02	450	
	35/L	3201.12.0276V22		3201.12.0274V10	700	
	35/L	3201.12.0276V17		3201.12.0274V08	300	125-250
	35/L	3201.12.0276V07		3201.12.0274V04	450	
	35/L	3201.12.0276V27		3201.12.0274V12	700	

DOOR TYPE TIPO PORTA	CO / PL						NH	CAM OFFSET [mm] DISASSAMENTO [mm]
	600	650	700	750	1500	OVER OLTRE		
	72/R				3201.12.0274V05		300	0-100
	72/R				3201.12.0274V01		450	
	72/R				3201.12.0274V09		700	
	72/R				3201.12.0274V07		300	125-250
	72/R				3201.12.0274V03		450	
	72/R				3201.12.0274V11		700	
	72/L				3201.12.0274V06		300	0-100
	72/L				3201.12.0274V02		450	
	72/L				3201.12.0274V10		700	
	72/L				3201.12.0274V08		300	125-250
	72/L				3201.12.0274V04		450	
	72/L				3201.12.0274V12		700	

Optionals with car door lock
Accessori con bloccaggio fuori piano

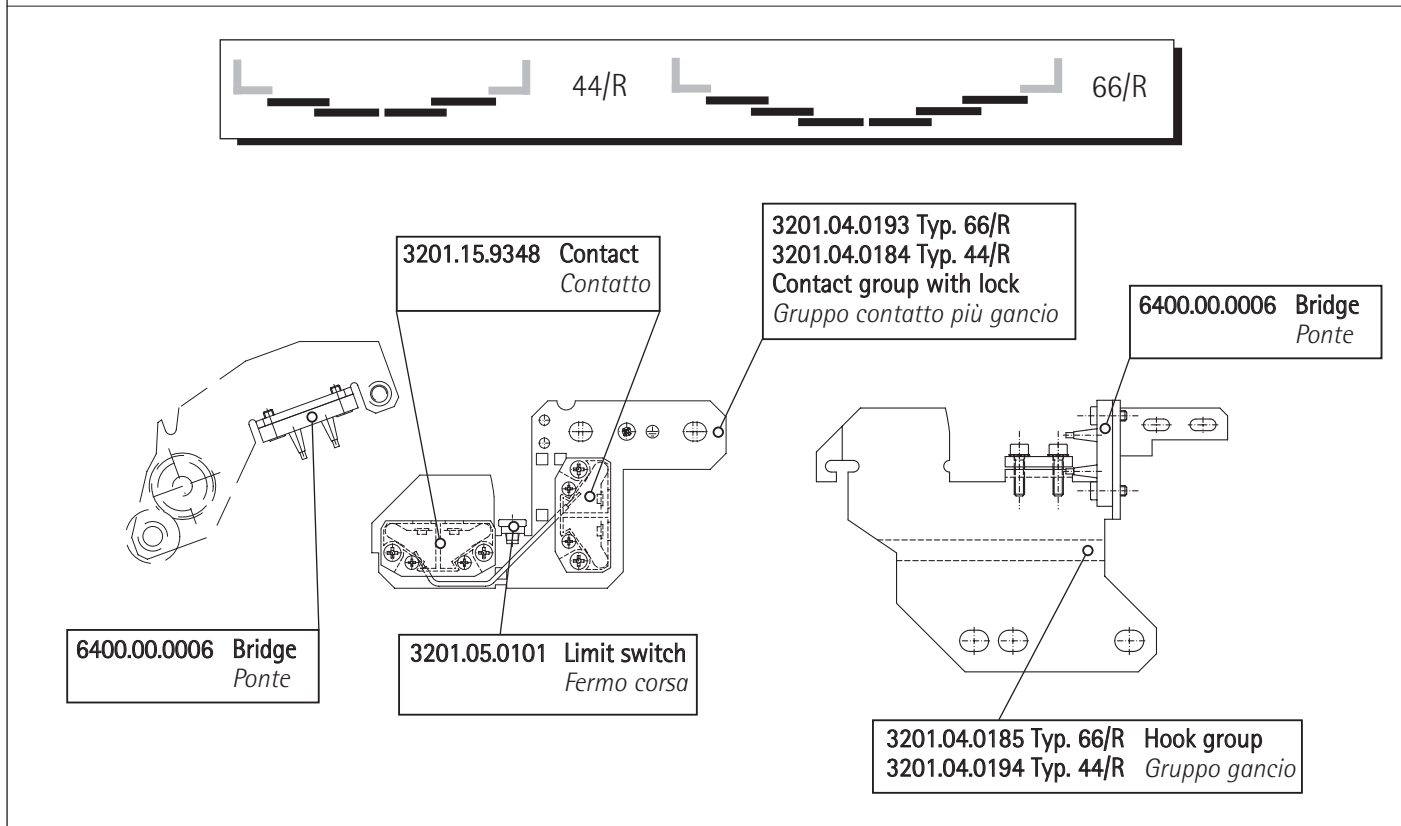
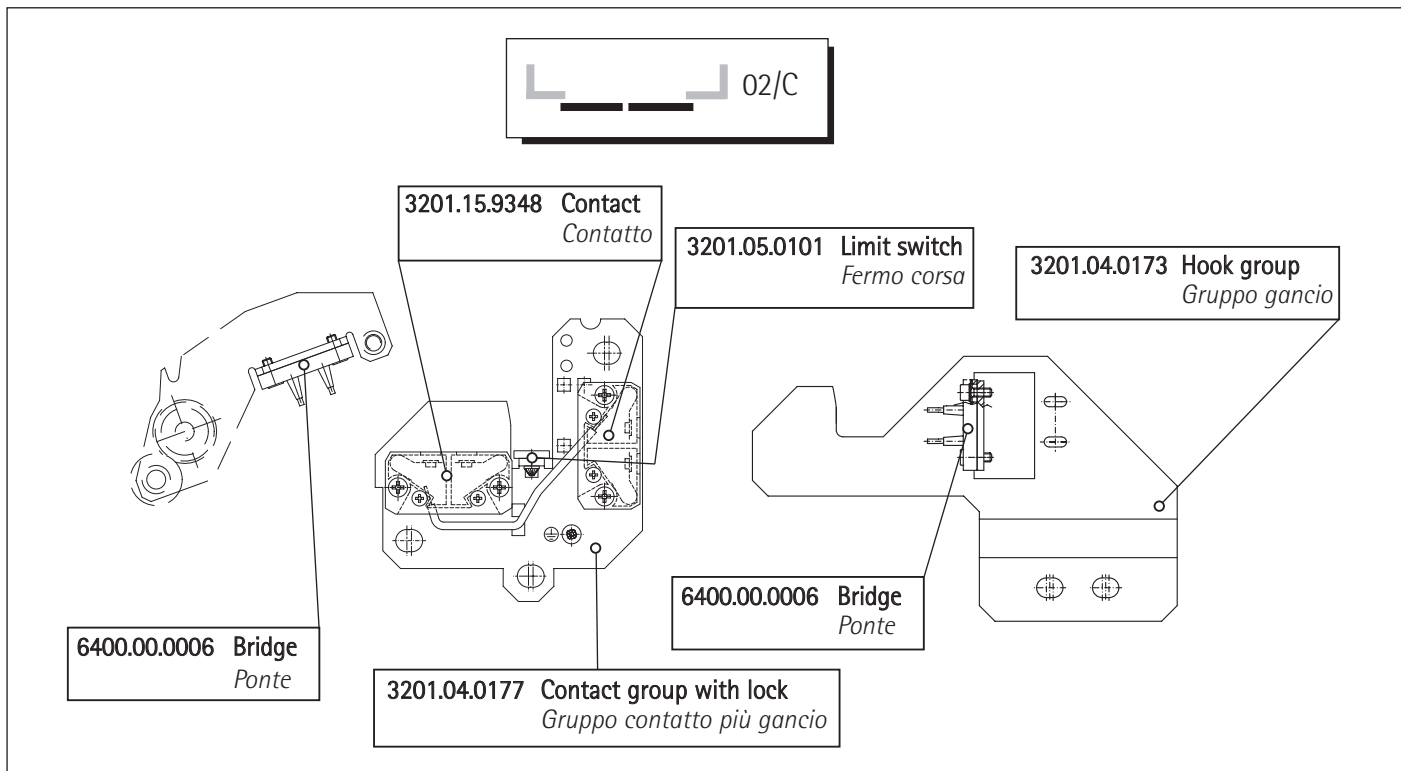

Optionals with car door lock
Accessori con bloccaggio fuori piano

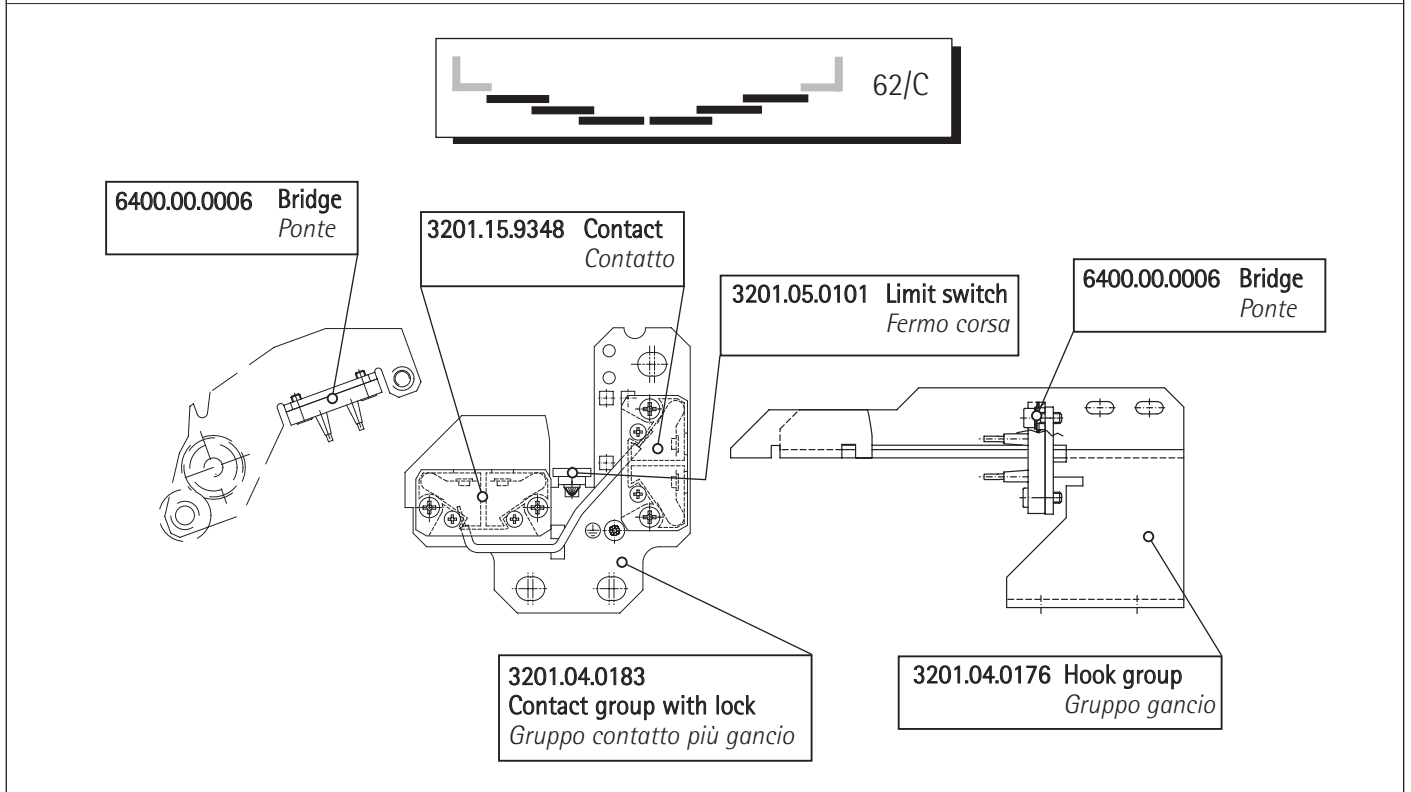
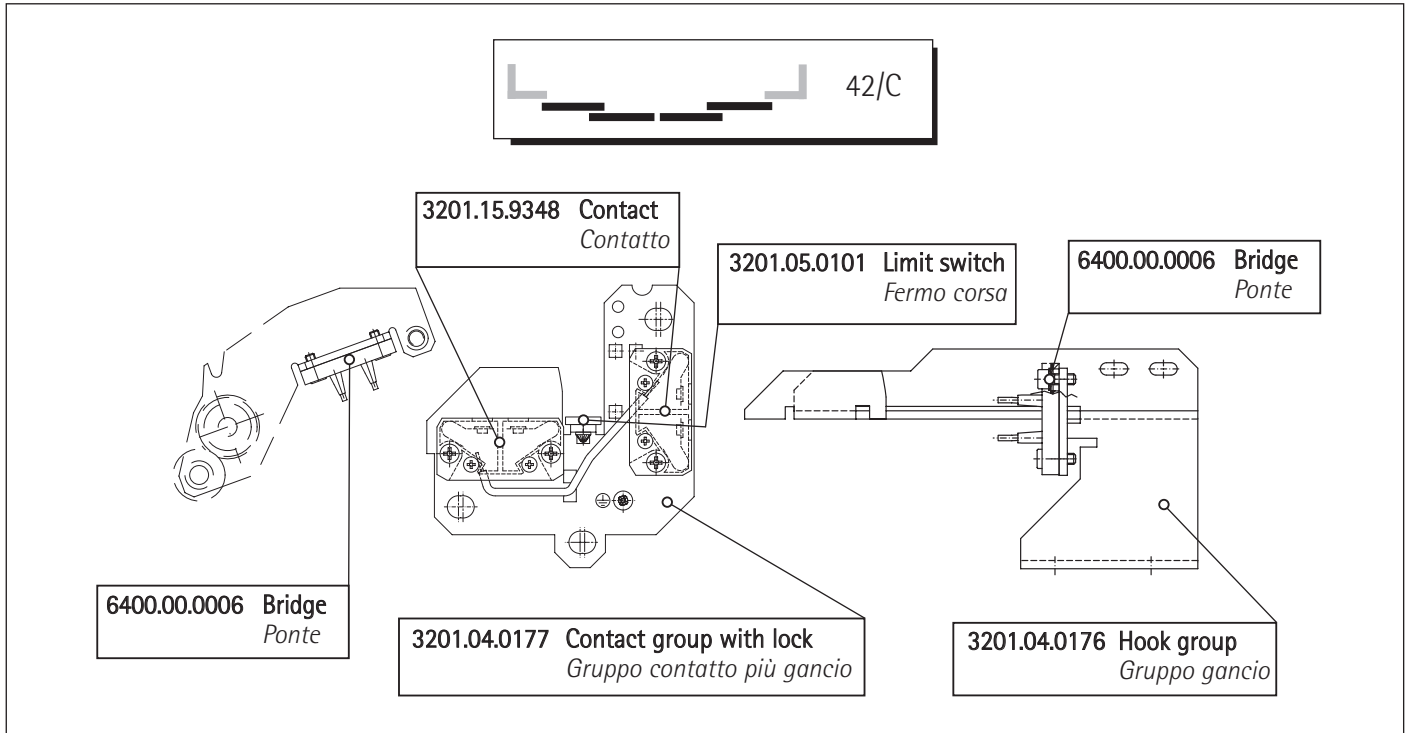

Optionals with car door lock
Accessori con bloccaggio fuori piano

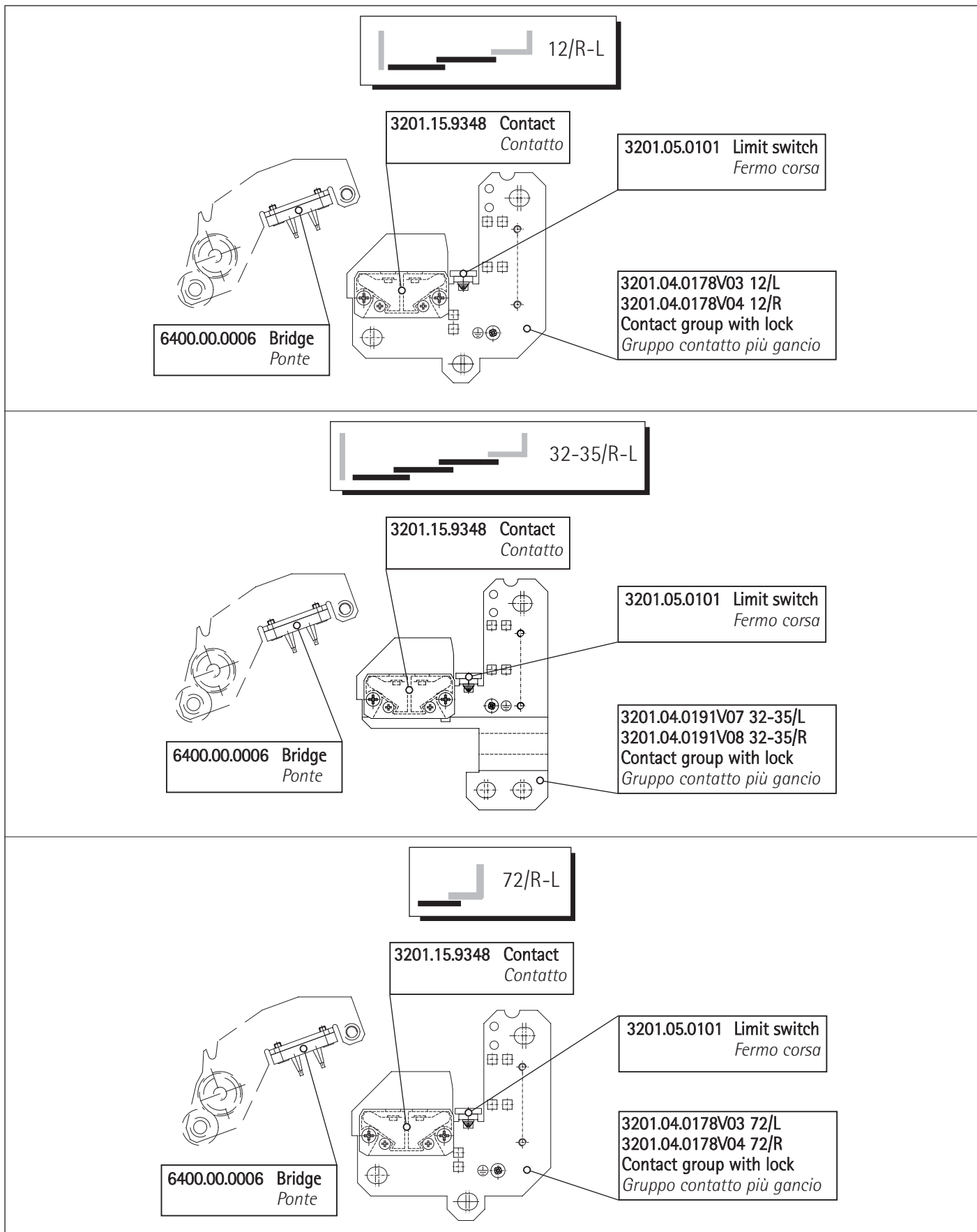

Aluminium sill
Soglie in alluminio

3201.05.7093 Please give door clear opening
Specificare il passaggio libero

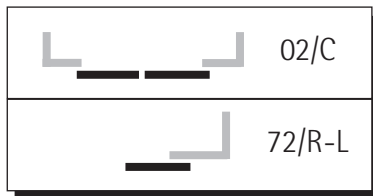
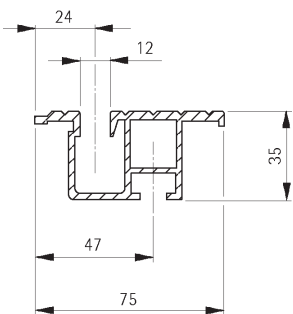

3201.05.7011 Please give door clear opening
Specificare il passaggio libero

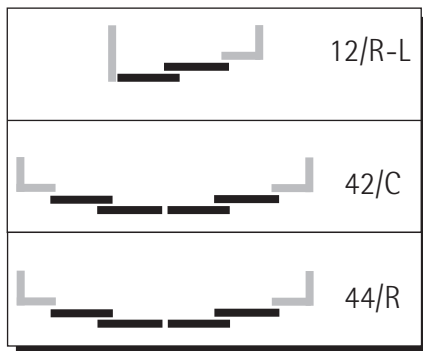
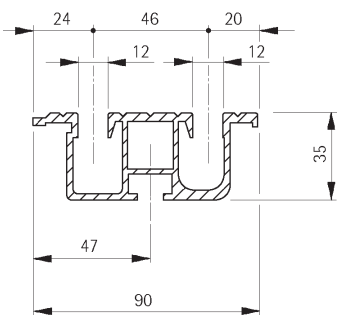

3201.05.7045 Please give door clear opening
Specificare il passaggio libero

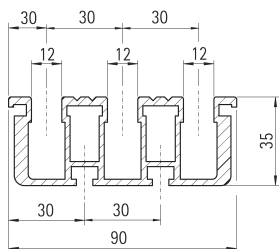

3201.05.7094 Please give door clear opening
Specificare il passaggio libero

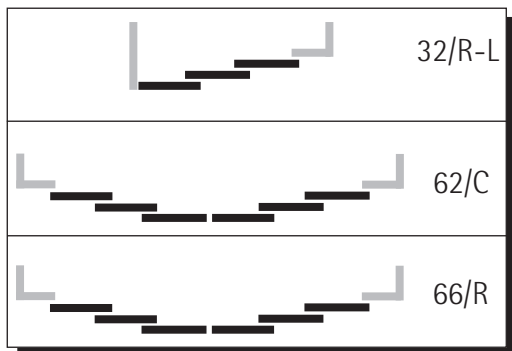
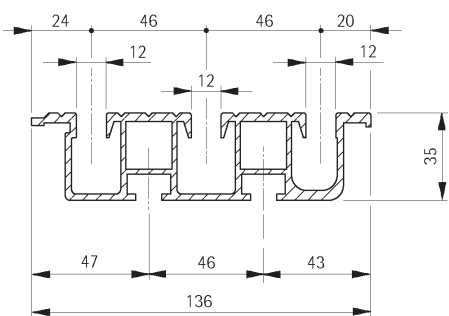

Spare parts for towed cable
Ricambi funi



3201.05.4001 Towed cable for side opening door
Fune per tiro in taglia

Coupling cable for center opening door
Fune di accoppiamento carrelli per porte ad apertura centrale

Specify IR
(IR=Distance between roller centers)
Specificare IR
(IR=Interasse rotelle)

3201.04.0245 Bernstein contact + selcom bridge
Contatto Bernstein + ponte selcom

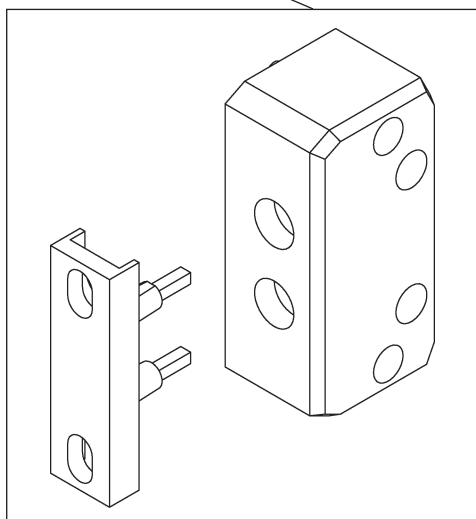

3201.03.0143 Bottom shoe
Pattino



Mechanical release type 1118 - Side opening car doors
Sblocco meccanico tipo 1118 - Porte di cabina ad apertura laterale

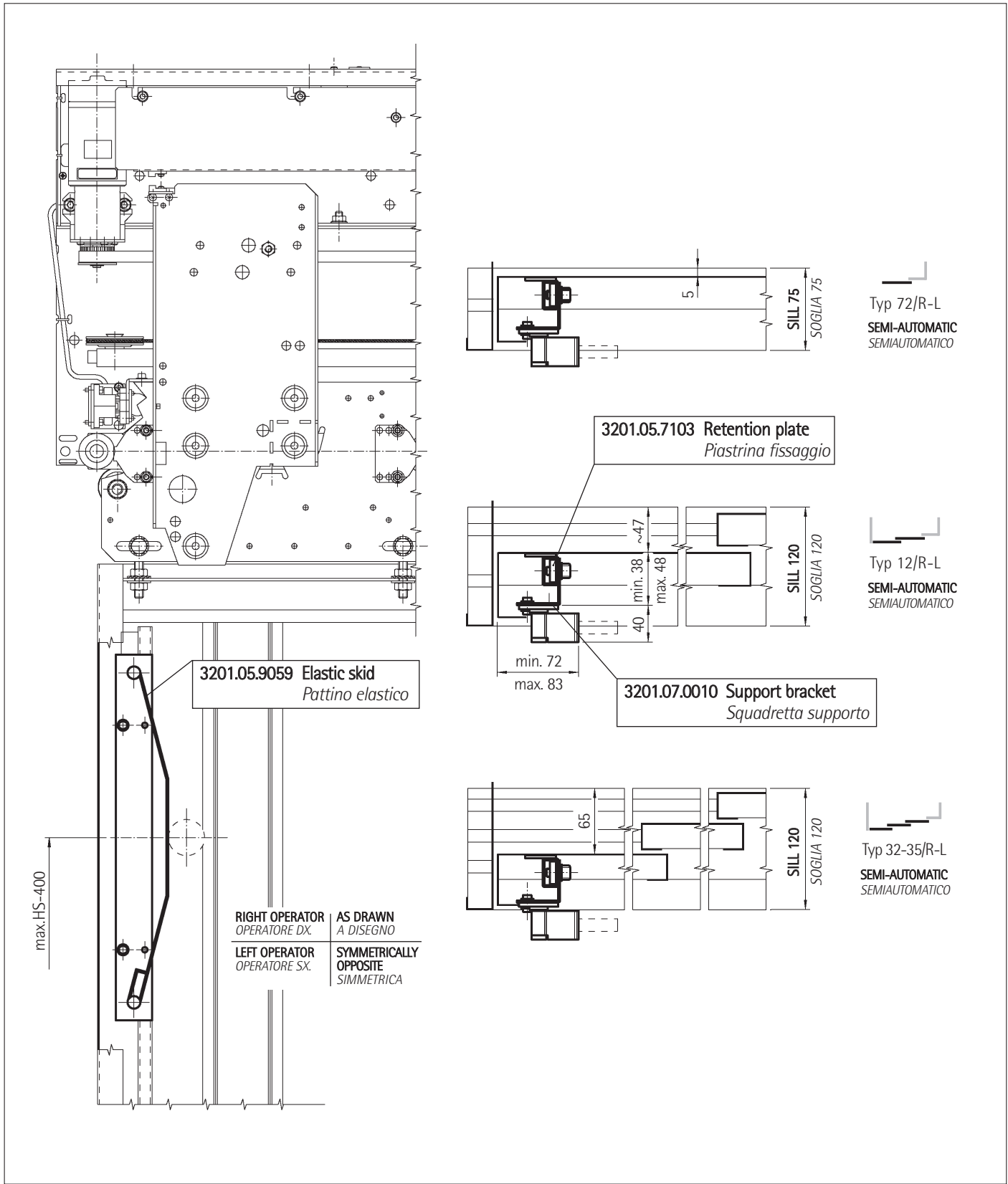

Mechanical release type 1119 - Centre opening car doors
Sblocco meccanico tipo 1119 - Porte di cabina ad apertura centrale

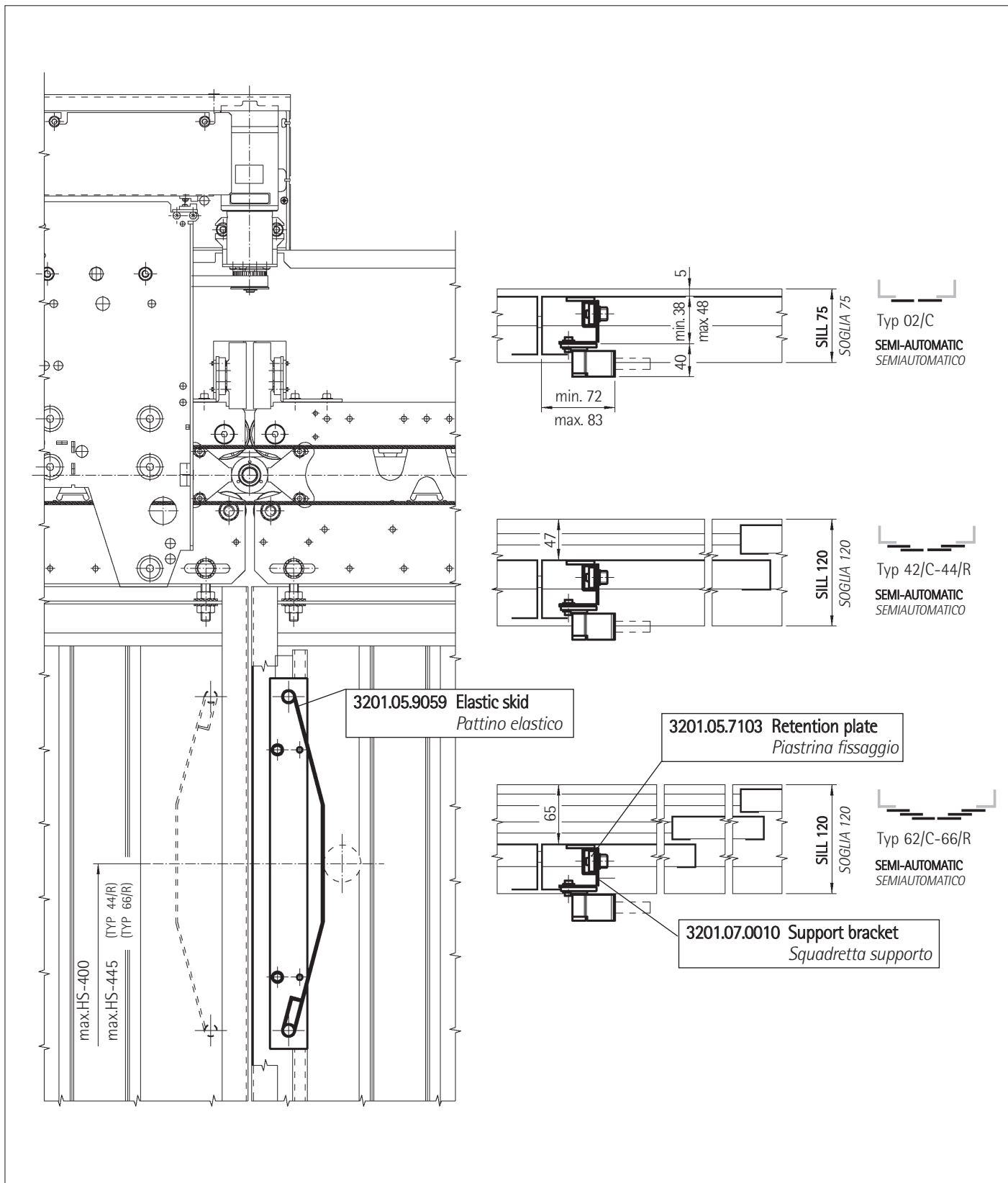

Mechanical release type 1200 for car doors
Sblocco meccanico tipo 1200 per porte di cabina

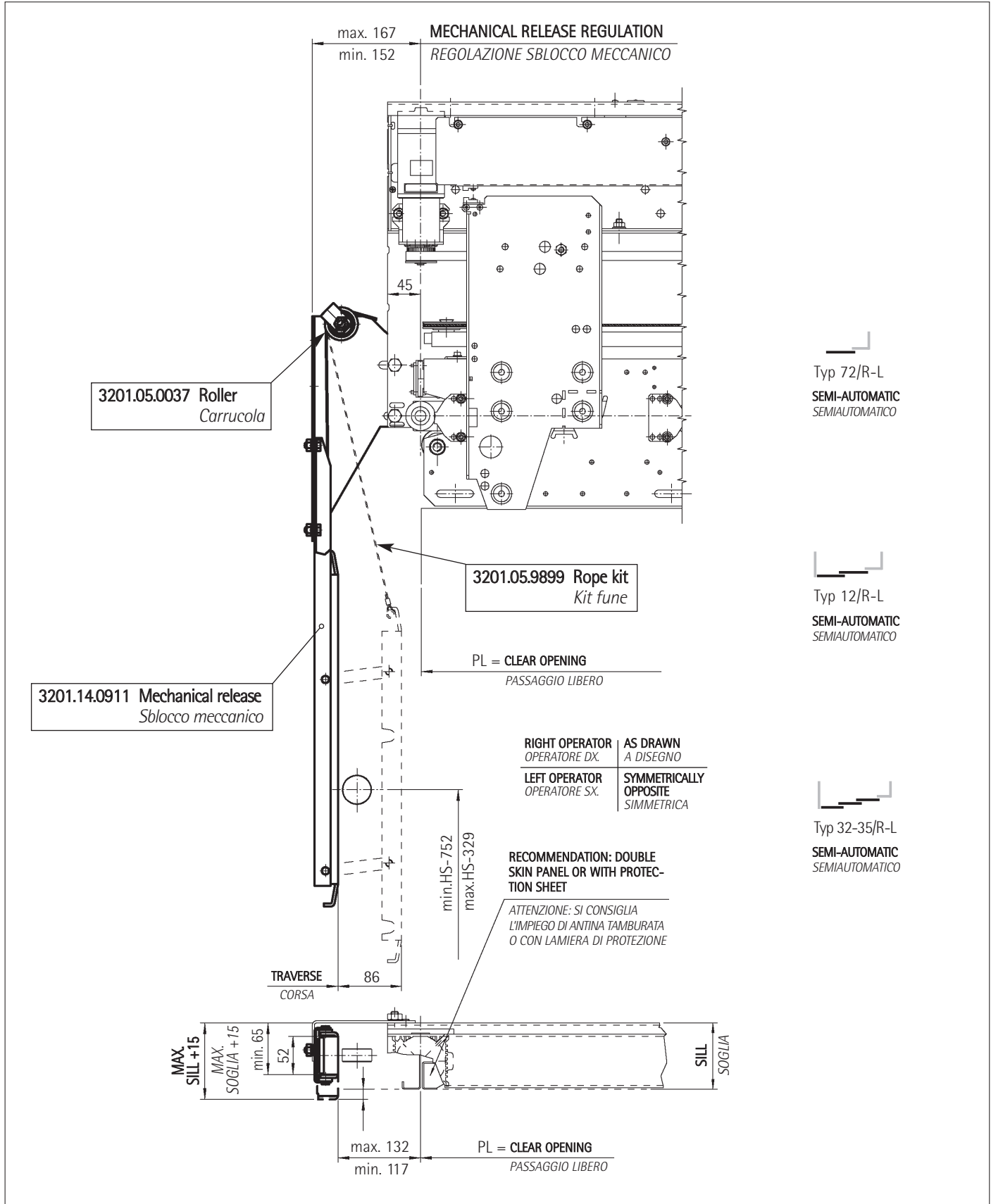

Typ 72/R-L
 SEMI-AUTOMATIC
 SEMIAUTOMATICO

Typ 12/R-L
 SEMI-AUTOMATIC
 SEMIAUTOMATICO

Typ 32-35/R-L
 SEMI-AUTOMATIC
 SEMIAUTOMATICO

Mechanical release type 1201 for car doors
Sblocco meccanico tipo 1201 per porte di cabina

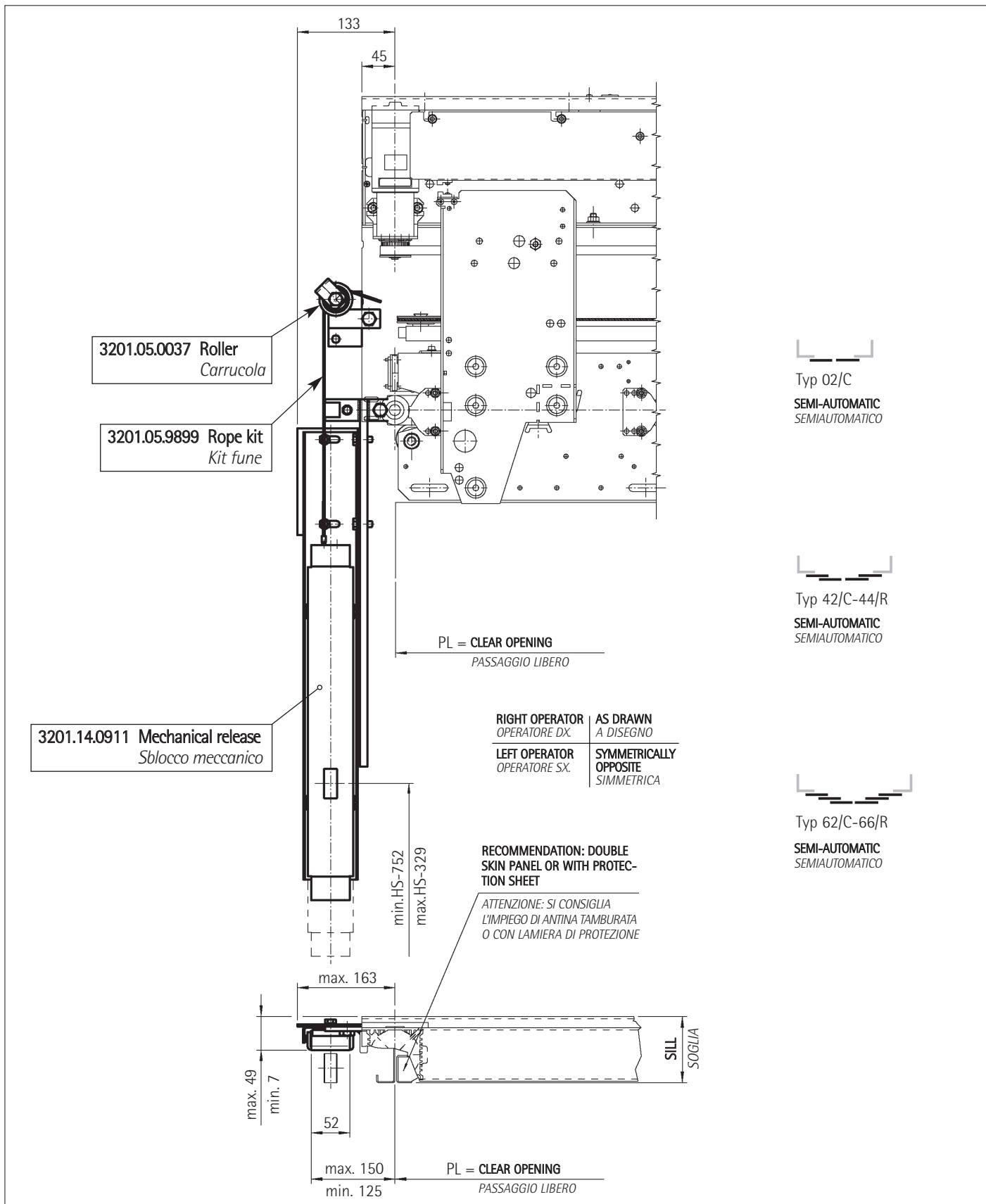

Mechanical release type 1202 for car doors
Sblocco meccanico tipo 1202 per porte di cabina

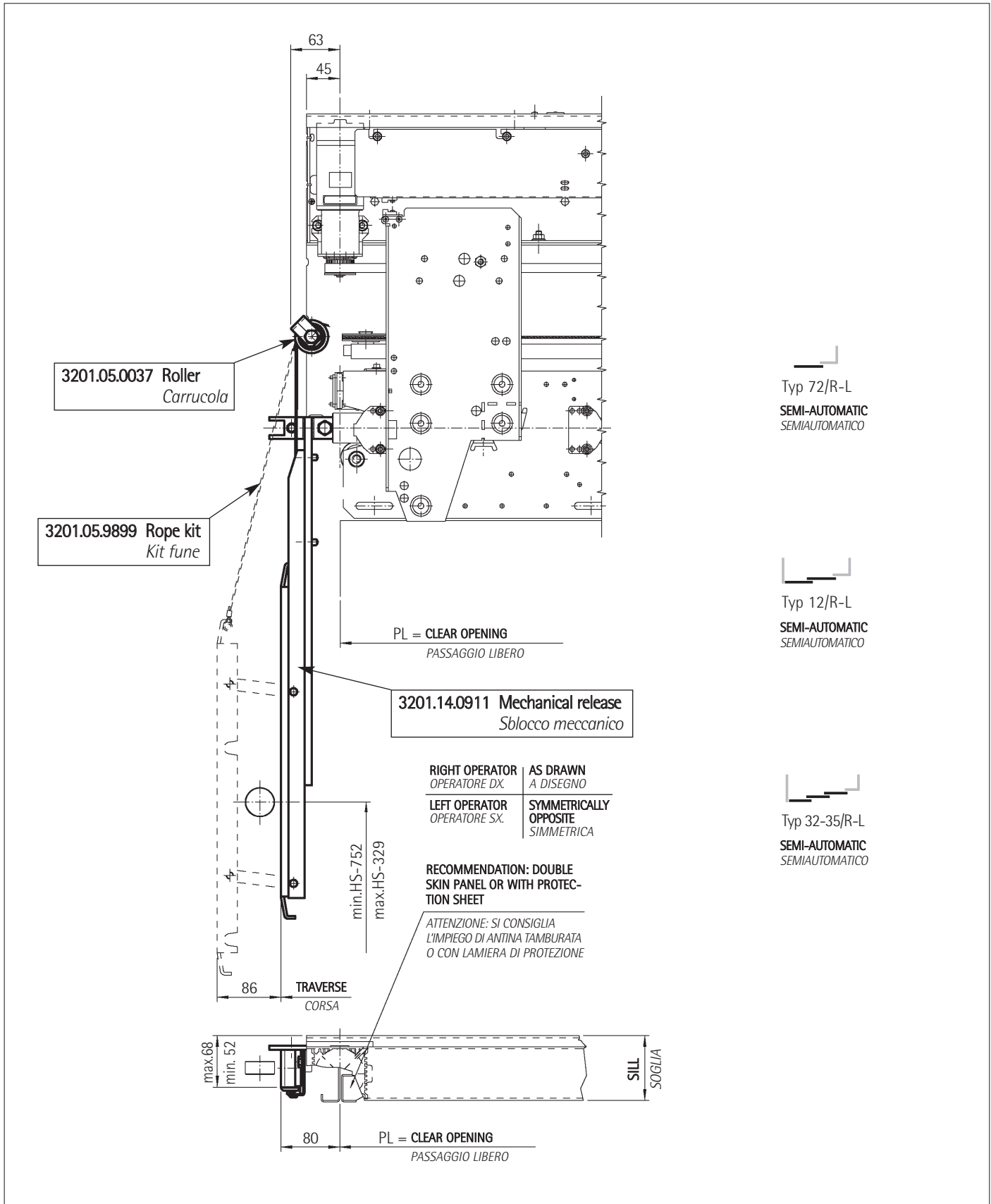

Typ 72/R-L
SEMI-AUTOMATIC
 SEMIAUTOMATICO

Typ 12/R-L
SEMI-AUTOMATIC
 SEMIAUTOMATICO

Typ 32-35/R-L
SEMI-AUTOMATIC
 SEMIAUTOMATICO

Cable chain assembly for central opening doors
Montaggio guidacavi per porte ad apertura centrale

Typ 02/C

Typ 42/C-44/R

Typ 62/C-66/R

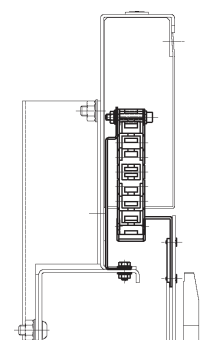
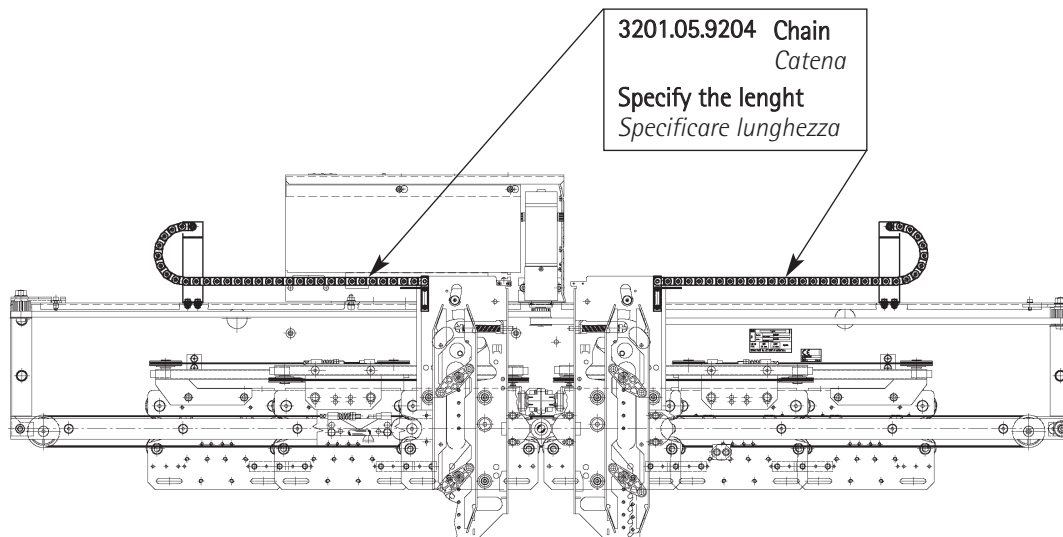
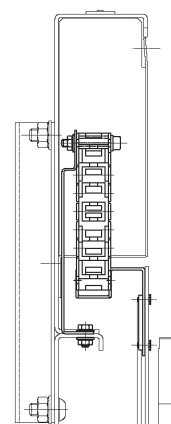
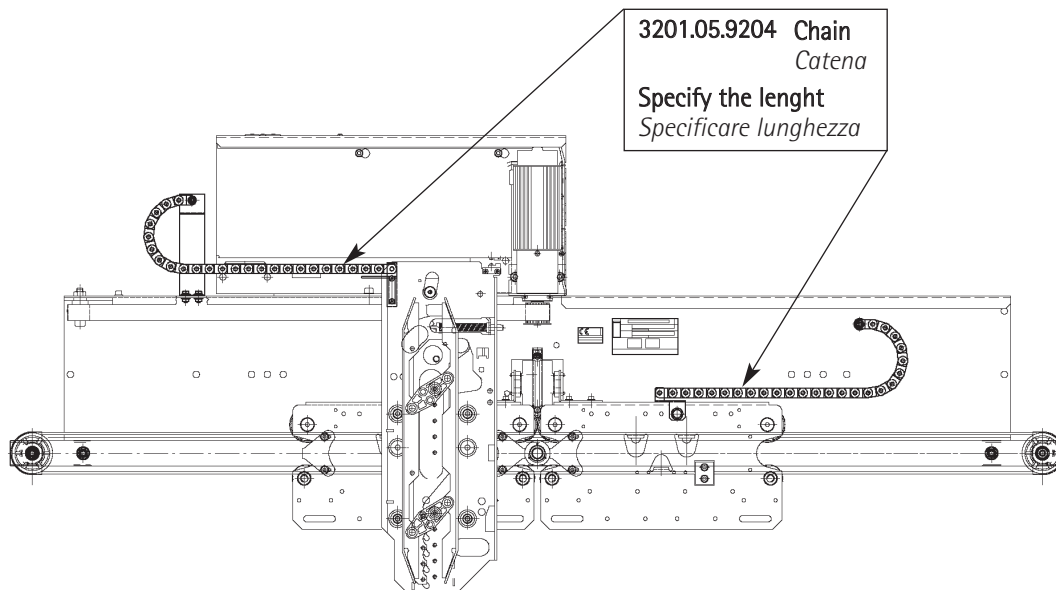

Cable chain assembly for side opening doors
Montaggio guidacavi per porte ad apertura laterale

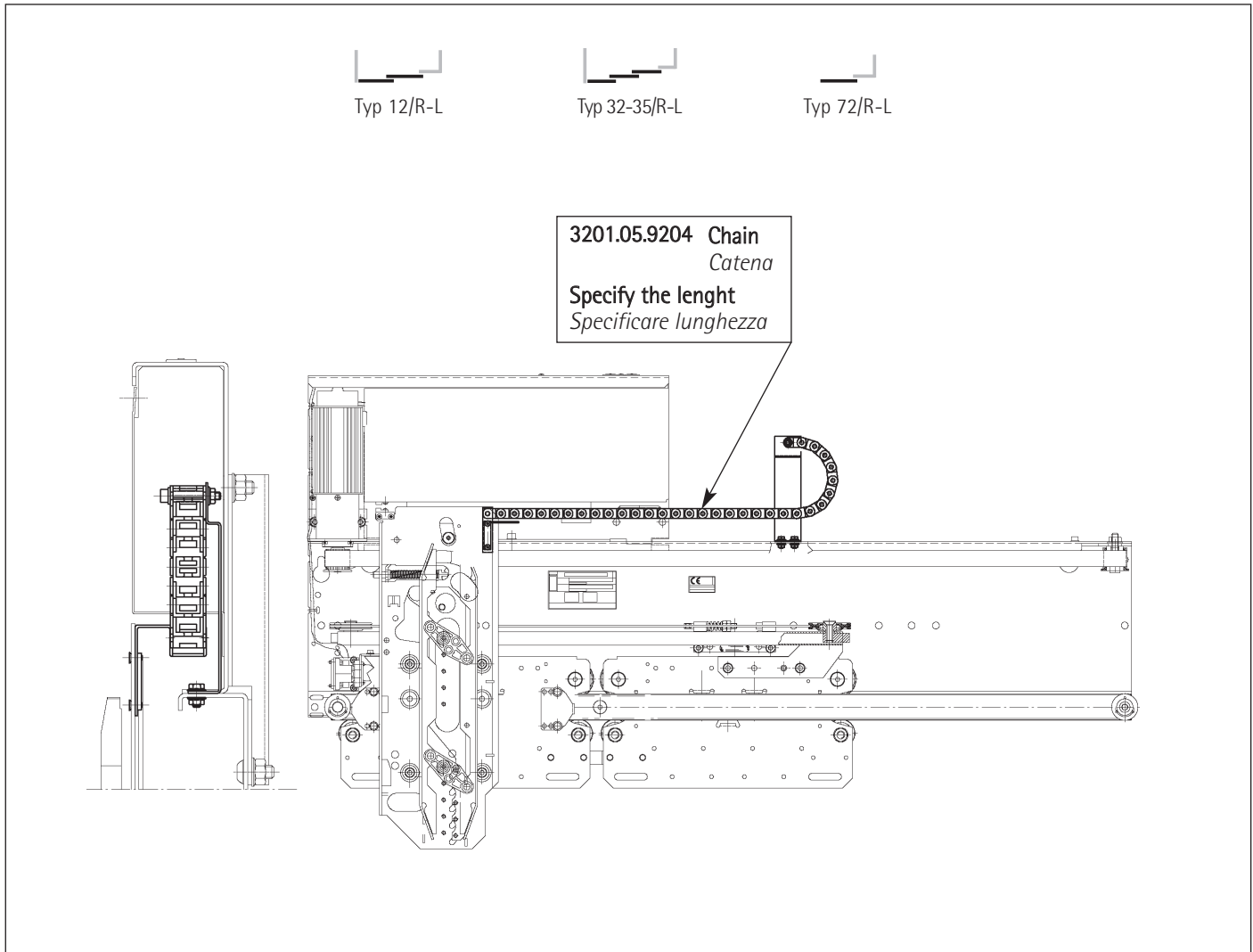

LSE edge assembly for side opening doors
Montaggio costola LSE per porte ad apertura laterale

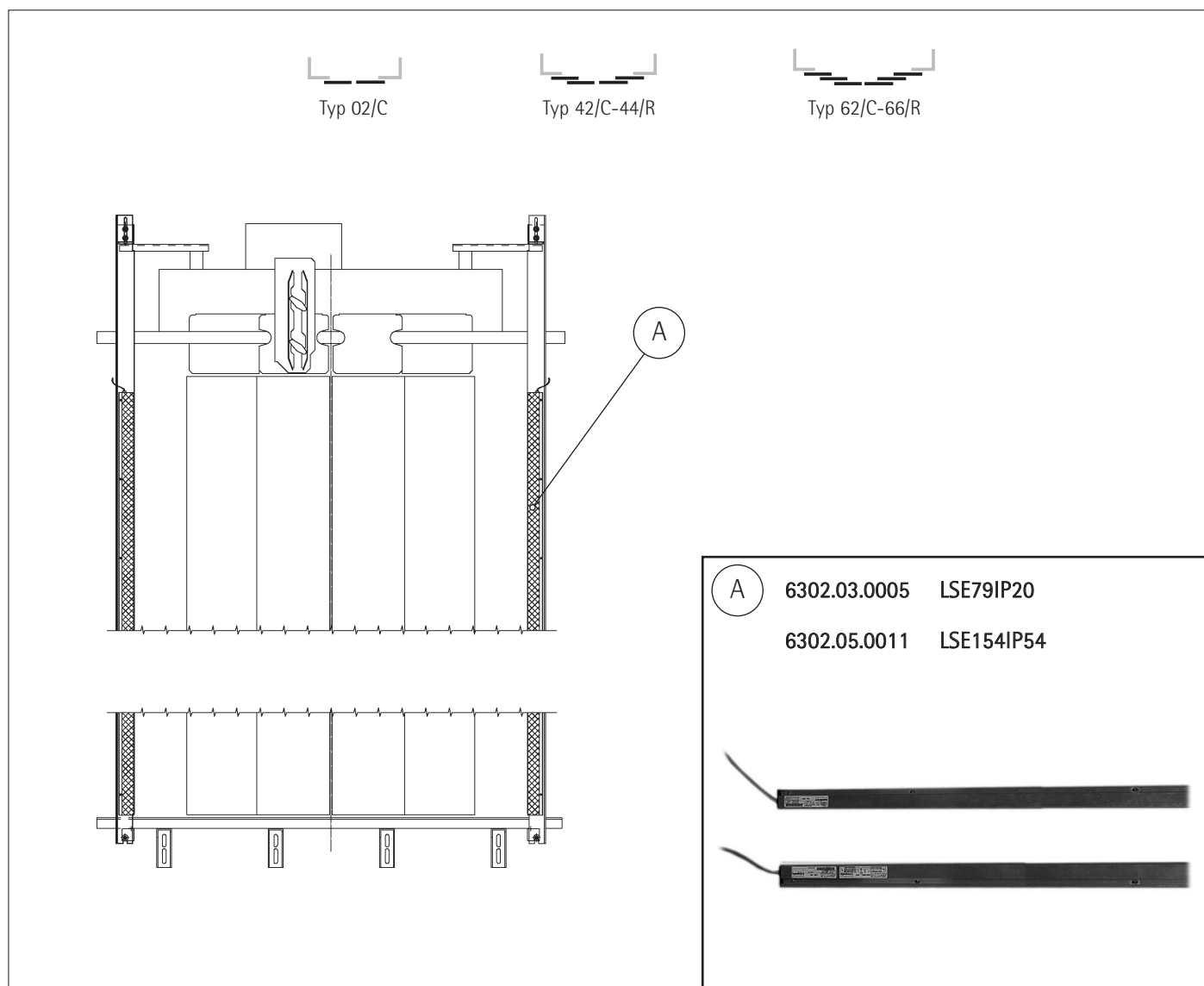

LSE edge assembly for central opening doors
Montaggio costola LSE per porte ad apertura centrale

